

MA[&]DE

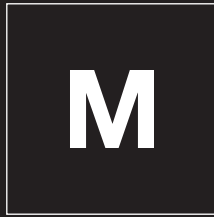

material

A company has a design philosophy defined by its history and challenges ahead, the road traveled and still to go. Linea Light Group for over thirty years conceived light as a material wherewith build environments and define spaces. Four collections narrating the progress, indulging the vocation: make the best possible light both functional and emotional. MA[&]DE is the collection that, more than any other, unites design and technology, a project philosophy built with designers' collaboration, defining a functional beauty ideal. Light is always an open challenge.

An identity. The MA[&]DE identity lies in an innovative design's concept characterizing all collection's creation. A technologic design, not for its own sake, adds real plus to products, making them aesthetically sophisticated and highly functional. Meticulous attention to the smallest details is associated to the research for the perfect joint for a movable parts smoother movement. Attention to the aesthetic, elegant and minimal lines with non-invasive technologies allow designers to use the product's full potential, in any context. A clear and effective response to the different fixture's use taking place in a single environment.

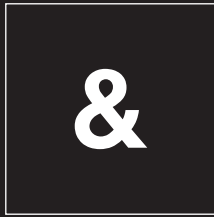



We spent years in continuous research on the best LED technology, working with higher materials and quality processes. Intense and rigorous researches applied to a contemporary design make MA[&]DE a reference collection in the global market. Our know-how evolved over time, the constant confrontation with professionals, led us to develop new lighting solutions to solve all their project needs. The recent year's evolutions led us to a new innovative light awareness.

Warm Tune™ The ideal space, the most suitable atmosphere. Varying the light intensity, changing the color temperature: intense and bright lighting or smooth and warm, customizable for every lighting needs.

OptiLight Technology™ Technology becomes esthetic. An innovative luminous flux distribution using ad hoc textures, laser engraved on diffuser's surface. Esthetically refined micro engravings, disappearing when light off, for maximum transparency. Deviating photons when light on, directing luminous beam optimally.

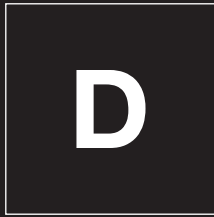

design

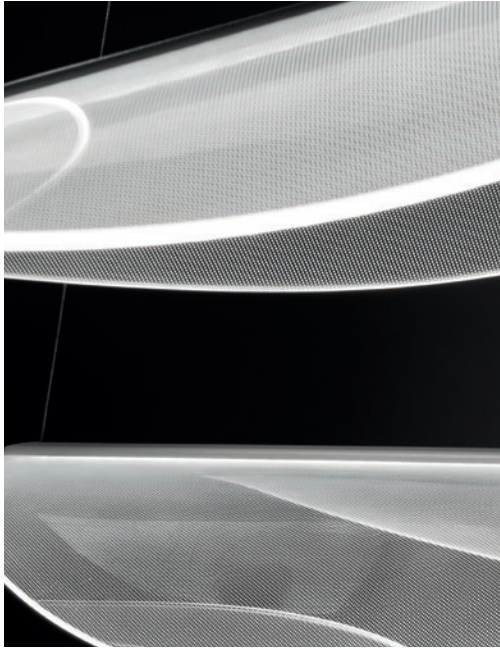

Designing a lamp includes several elements, closely related to each other: more than in any other object form and function are tightly bound. The technology core is wrapped by a material body, with a single task, complete with its shape the emotion of light. For us, a lamp design goes beyond mere aesthetics, it's materials, finishes research and the better way to incorporate the light. The company is supported by architects and designers, who shared our project vision. The MA[&]DE lamps are born from an idea of "real beauty". Extremely refined creations, which provide answers both functional and aesthetic requirements for the most diverse areas, from residence to large hotels.

Innovation is the road that we walk daily. Our laboratories face many challenges every day, challenging and stimulating. We work to ensure maximum efficiency in terms of performance, using top-quality and always last generation diodes, all CRI90 for the better color reproduction. We have a constant dialogue with the main lighting professionals to anticipate materials and esthetical trends. Guide lines from which to mold performative and durable lamps. MA[&]DE means Material & Design. MA[&]DE is furnishing with light.

5

YEARS WARRANTY

Linea Light Group offers a 5-year warranty on its products against manufacturing defects, subject to filling in the activation form available at www.linealight.com. In the absence of activation, the statutory warranty remains valid.

All power supply, wiring and accessories used for product installation shall be original Linea Light Group parts or approved by the company. The warranty will become void if non original or non approved parts are used.

For more information, please visit our website www.linealight.com

MA_[&]DE

MATERIAL
& DESIGN
LIGHTING

Product Index



Oxygen

P. 12

Pendant | Ceiling | Wall | Floor



Tablet

P. 28

Pendant | Ceiling | Wall

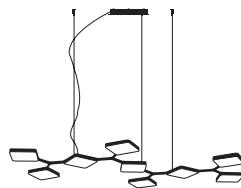

Quad

P. 44

Pendant | Wall



Mongolfier

P. 56

Pendant



Saturn

P. 120

Pendant | Ceiling | Wall



Kyklos

P. 132

Pendant | Wall



Oblix

P. 144

Ceiling | Wall



Square

P. 154

Pendant | Ceiling

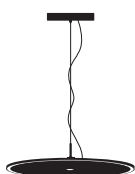

Light Game

P. 224

Pendant | Ceiling

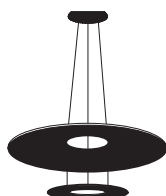

Madame Blanche

P. 234

Pendant



Branch

P. 244

Pendant



Monarque

P. 254

Pendant



Eclips

P. 306

Ceiling | Wall



Dunia

P. 316

Pendant | Ceiling



Dynamic

P. 326

Ceiling | Wall



Circle Wave

P. 66

Pendant | Ceiling



2Nights

P. 78

Wall



Moonflower

P. 90

Wall



Lama

P. 106

Pendant | Ceiling | Wall |
Floor | Table



Entourage

P. 168

Pendant

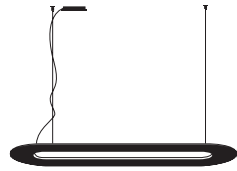

Opti-Line

P. 182

Pendant

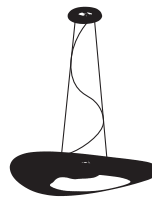

Mr.Magoo

P. 192

Pendant | Ceiling | Floor



Xilema

P. 208

Pendant | Ceiling | Wall | Floor



Next

P. 264

Pendant | Ceiling | Wall



Diphy

P. 276

Pendant | Floor



Wings

P. 286

Wall



Flurry

P. 296

Ceiling | Wall





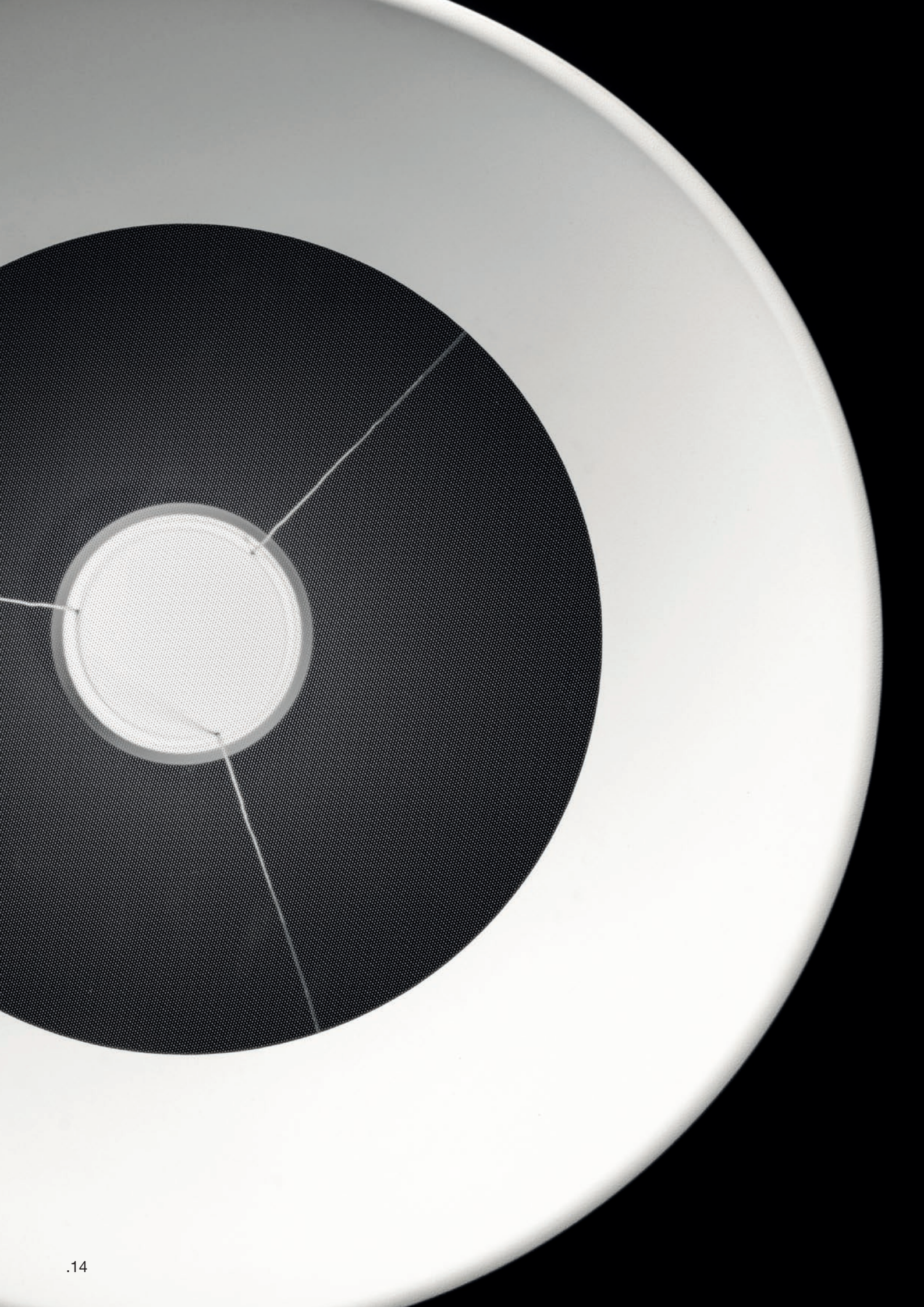

Air and light slight ring. Archetypic and recognizable geometry. Available in five options: suspension, wall lamp, curved or vertical standing light and ceiling version. Near the black or white finishes, a vibrant yellow and pale blue. Located inside the polyurethane lampshade, the micro engraved PMMA diffuser deflects the light beams from the surrounding sources. The OptiLight Technology™ defines an elegant and transparent weave, emphasizing diffuser's esthetic, completely transparent and invisible when light off

.Oxygen

design Pio & Tito Toso, 2016





SAY SOMETHING SILLY
LAUGH TIL IT HURTS
TAKE A RISK
TELL A SECRET
SING OUT LOUD
ROCK THE BOAT
SHAKE THINGS UP
FLIRT WITH DISASTER
BUY SOMETHING FRIVOLOUS
COLOR
OUTSIDE THE LINES
CAUSE A SCENE
ORDER DESSERT
MAKE WAVES
GET CARRIED AWAY
HAVE A GREAT DAY











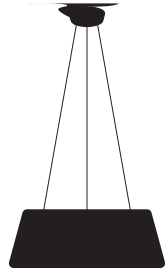

Technical Info

Oxygen_P | Pendant luminaires | 220-240 V | topLED 36 W

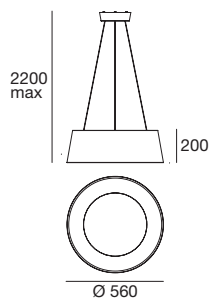

type

Wh.	Wh.	CRI 90	8089
Bl.	Wh.	CRI 90	8090
Yel.	Wh.	CRI 90	8091
Azul	Wh.	CRI 90	8092

colour

3000 K 4042 lm

optics

diffused

Oxygen_P | Pendant luminaires | 220-240 V | topLED 50 W

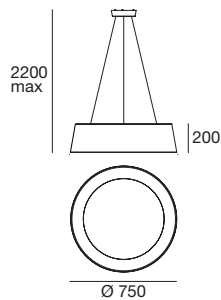

type

Wh.	Wh.	CRI 90	8093
Bl.	Wh.	CRI 90	8094
Yel.	Wh.	CRI 90	8095
Azul	Wh.	CRI 90	8096

colour

3000 K 5670 lm

optics

diffused

Oxygen

Yellow | White finish



Oxygen_S | Ceiling luminaires | 220-240 V | topLED 36 W

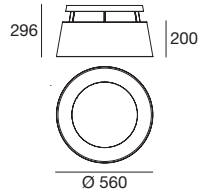

type

Wh.	Wh.	CRI 90	8081
Bl.	Wh.	CRI 90	8082
Yel.	Wh.	CRI 90	8083
Azu.	Wh.	CRI 90	8084

colour

3000 K 4042 lm

optics

diffused

Oxygen_S | Ceiling luminaires | 220-240 V | topLED 50 W

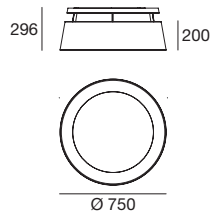

type

Wh.	Wh.	CRI 90	8085
Bl.	Wh.	CRI 90	8086
Yel.	Wh.	CRI 90	8087
Azu.	Wh.	CRI 90	8088

colour

3000 K 5670 lm

optics

diffused

Oxygen
Azure | White finish

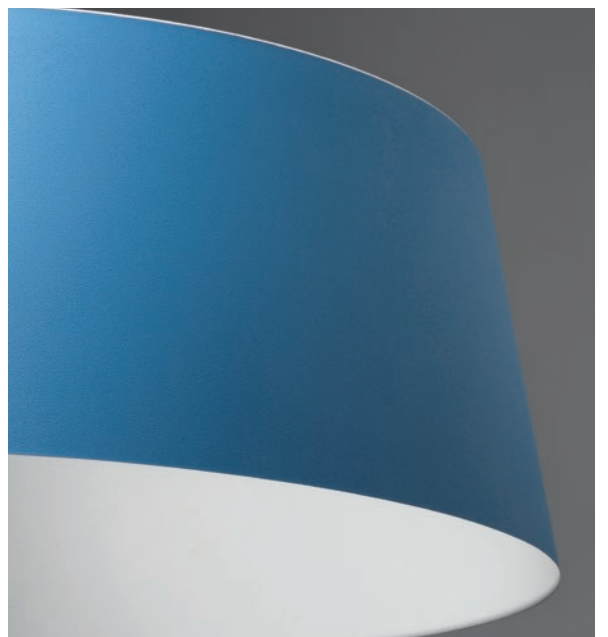

Oxygen_W | Wall light | 220-240 V | topLED 17 W

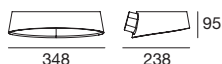

type

Wh.	Wh.	CRI 90	8105
Bl.	Wh.	CRI 90	8106
Yel.	Wh.	CRI 90	8107
Azul	Wh.	CRI 90	8108

colour

3000 K 2021 lm

optics

diffused

Oxygen_W | Wall light | 220-240 V | topLED 17 W

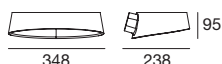

type

Wh.	Wh.	CRI 90	8185
Bl.	Wh.	CRI 90	8186
Yel.	Wh.	CRI 90	8187
Azul	Wh.	CRI 90	8188

colour

3000 K 2021 lm

optics

diffused

Oxygen_FL1 | Free Standing | 220-240 V | topLED 36 W

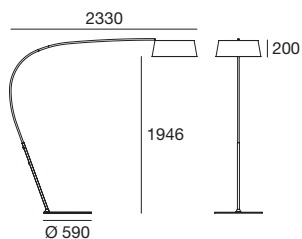

type

Wh.	Wh.	CRI 90	8101
Bl.	Wh.	CRI 90	8102
Yel.	Wh.	CRI 90	8103
Azul	Wh.	CRI 90	8104

colour

3000 K 4042 lm

optics

diffused

Oxygen_FL2 | Free standing | 220-240 V | topLED 36 W

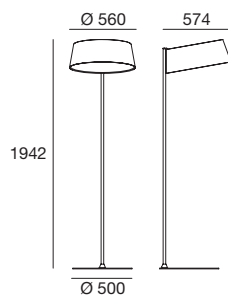
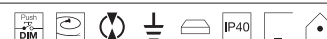

type

Wh.	Wh.	CRI 90	8097
Bl.	Wh.	CRI 90	8098
Yel.	Wh.	CRI 90	8099
Azul	Wh.	CRI 90	8100

colour

3000 K 4042 lm

optics

diffused

.Oxygen

.A ring shining from within,
a true synthesis of
form and essence.
It is the emblem of the difficult
art of simplicity,
a breath of fresh air away from
all that is unnecessary.



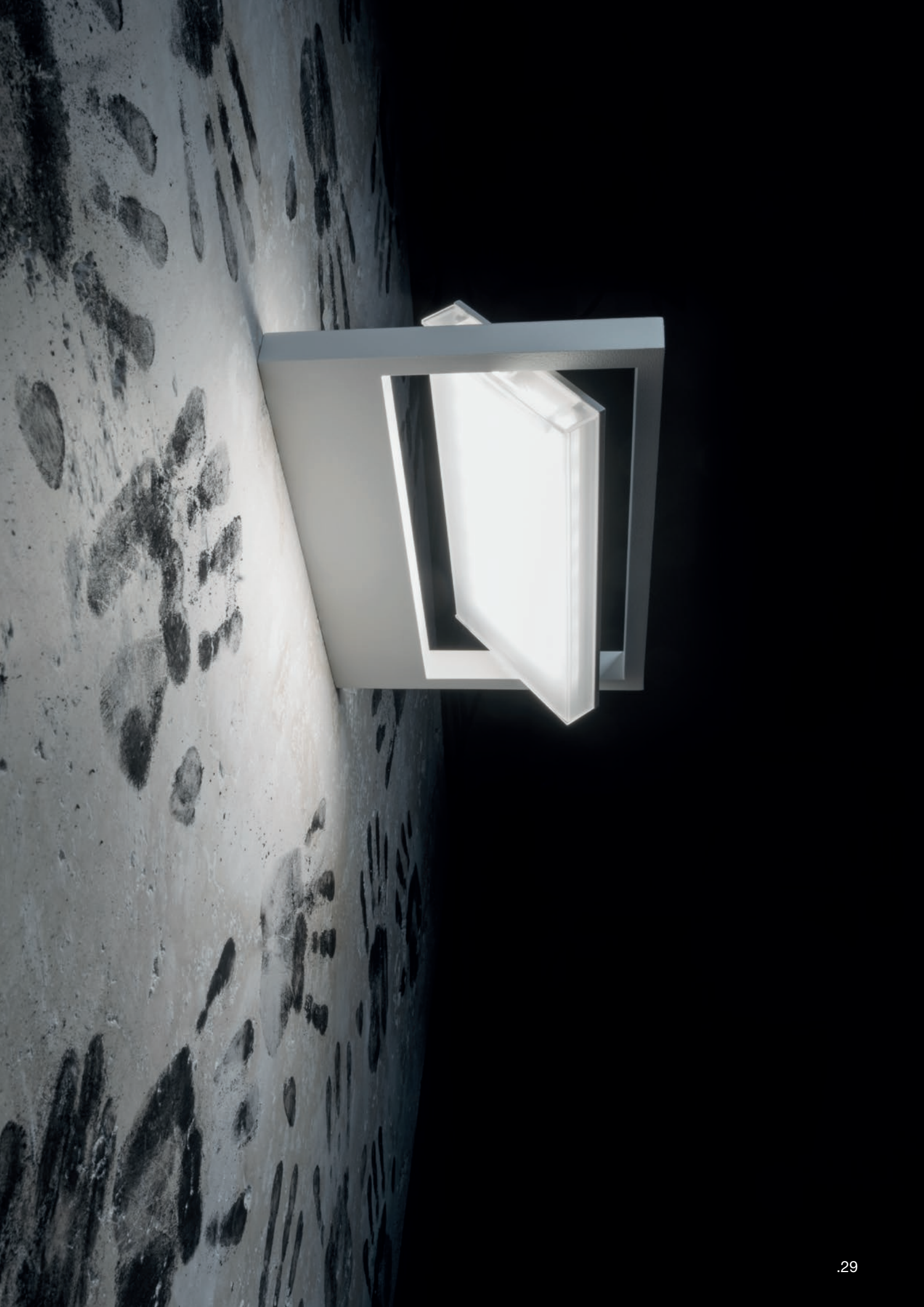



Light always on the move. Tablet provides a clear, grazing or diffusive lighting, displaced on turning axis. The aluminum support allows light beams and source orientation, granting a complete rotation, creating accent or wide lighting. Tablet is available suspension, freely composable, for side-by-side, staggered or crossed compositions; ceiling and wall mounted version W1 with single support and option W2 wall mounted with two independent rotating source supports, for asymmetric light beams

.Tablet

design Linea Light Group, 2014





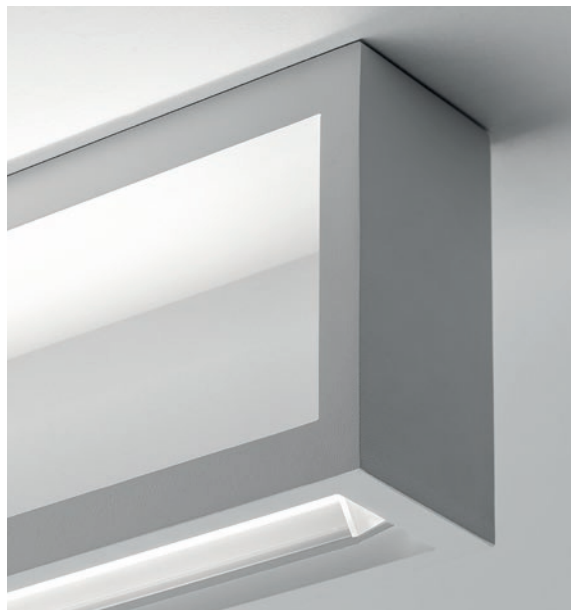







Technical Info

Tablet_P1 | Pendant luminaires | 220-240 V | topLED 18 W

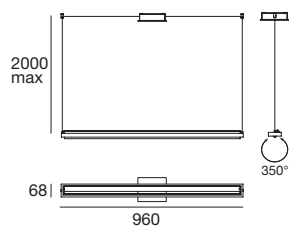

type

White	CRI 90	7593
Black	CRI 90	7594

colour

3000 K 2580 lm

optics

diffused

Tablet_P2 | Pendant luminaires | 220-240 V | topLED 41 W

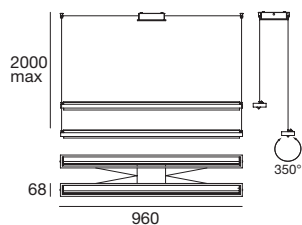

type

White	CRI 90	7598
Black	CRI 90	7599

colour

3000 K 5163 lm

optics

diffused

Tablet_S | Ceiling luminaires | 220-240 V | topLED 31 W

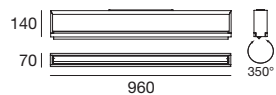

type

White	CRI 90	7595
Black	CRI 90	7596

colour

3000 K 3593 lm

optics

diffused

Tablet_W2 | Wall light | 220-240 V | topLED 19 W

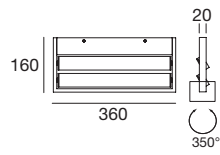

type

White	CRI 90	7606
Black	CRI 90	7613

colour

3000 K 2395 lm

optics

diffused

suggested accessories



KIT0046

Fixing bracket only for 7606



KIT0047

Fixing bracket only for 7613

Tablet_W2 | Wall light | 220-240 V | topLED 38 W

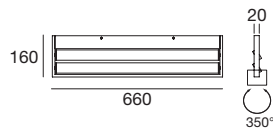
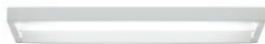

type

White	CRI 90	7607
Black	CRI 90	7614

colour

3000 K 4790 lm

optics

diffused

suggested accessories



KIT83

Fixing bracket only for 7607

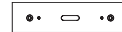

KIT0044

Fixing bracket only for 7614

cod. 7607
Tablet_W2
Wall Light



Tablet_W1 | Wall light | 220-240 V | topLED 5 W

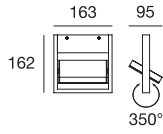

type

White	CRI 90	7600
Black	CRI 90	7608

colour

3000 K 557 lm

optics

diffused

suggested accessories



KIT80

Fixing bracket only for 7600



KIT0041

Fixing bracket only for 7608

Tablet_W1 | Wall light | 220-240 V | topLED 15 W

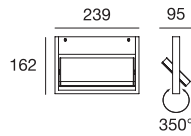

type

White	CRI 90	7601
Black	CRI 90	7609

colour

3000 K 1597 lm

optics

diffused

suggested accessories



KIT81

Fixing bracket only for 7601



KIT0042

Fixing bracket only for 7609

Tablet_W1 | Wall light | 220-240 V | topLED 19 W

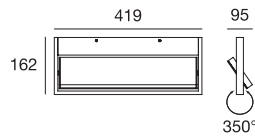

type

White	CRI 90	7602
Black	CRI 90	7610

colour

3000 K 2295 lm

optics

diffused

suggested accessories

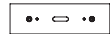

KIT82

Fixing bracket only for 7602

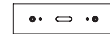

KIT0043

Fixing bracket only for 7610

Tablet_W1 | Wall light | 220-240 V | topLED 19 W

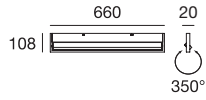

type

White	CRI 90	7604
Black	CRI 90	7611

colour

3000 K 2395 lm

optics

diffused

suggested accessories

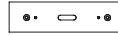

KIT83

Fixing bracket only for 7604

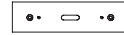

KIT0044

Fixing bracket only for 7611

Tablet_W1 | Wall light | 220-240 V | topLED 31 W

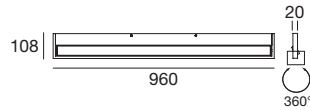

type

White	CRI 90	7605
Black	CRI 90	7612

colour

3000 K 3593 lm

optics

diffused

suggested accessories

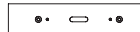

KIT84

Fixing bracket only for 7605

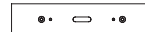

KIT0045

Fixing bracket only for 7612

cod. 7611
Tablet_W1
Wall Light



Tablet | fixing bracket

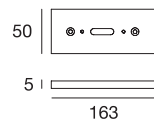
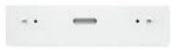

type

White	KIT80
Black	KIT0041

suitable for

7600
7608

Tablet | fixing bracket

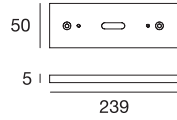

type

White	KIT81
Black	KIT0042

suitable for

7601
7609

Tablet | fixing bracket

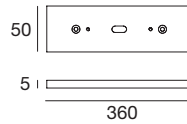

type

White	KIT0046
Black	KIT0047

suitable for

7606
7613

Tablet | fixing bracket

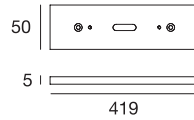
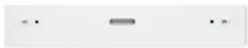

type

White	KIT82
Black	KIT0043

suitable for

7602
7610

Tablet | fixing bracket

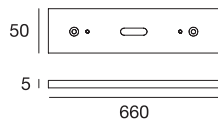

type

White	KIT83
Black	KIT0044

suitable for

7604-7607
7611-7614

Tablet | fixing bracket

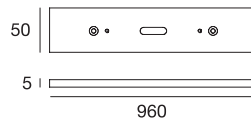

type

White	KIT84
Black	KIT0045

suitable for

7605
7612

.Tablet



.Inspired by the most popular
tablet worldwide,
a perennially lit,
highly technological screen
that can be directed
wherever you like.





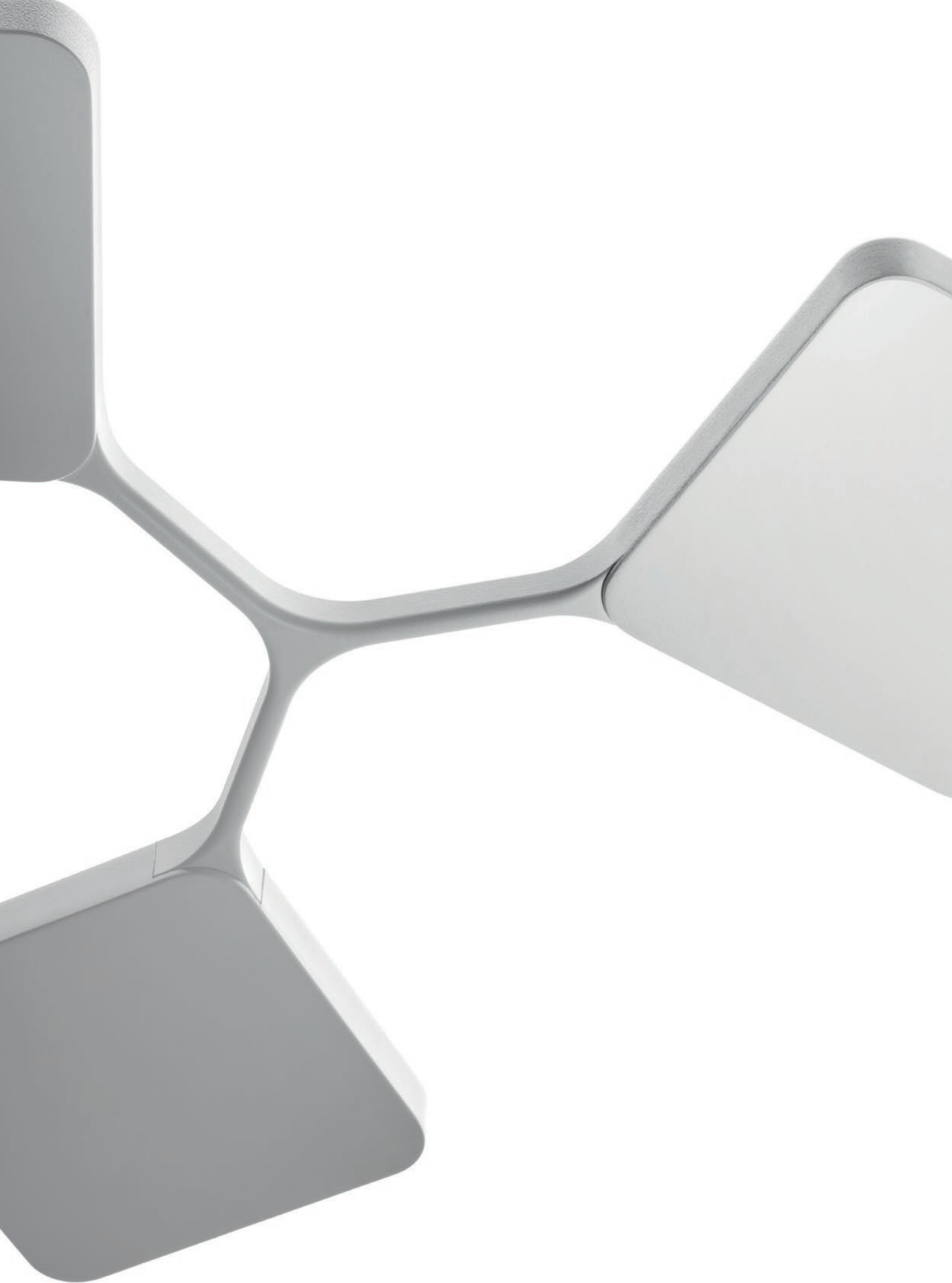

Modular simplicity. Two shifting squares, merging at right angle in a unique plastic structure. Aluminum case holds the LED source, with its rounded and simple shape, it's a perfect synthesis between dynamicity and smoothness. The applique is modular, for multiple linear and geometric installations, with a great impact lighting perception. Three new suspensions are available, modular and articulates, perfect for horizontal surfaces or open space

.Quad

design Pio & Tito Toso, 2014

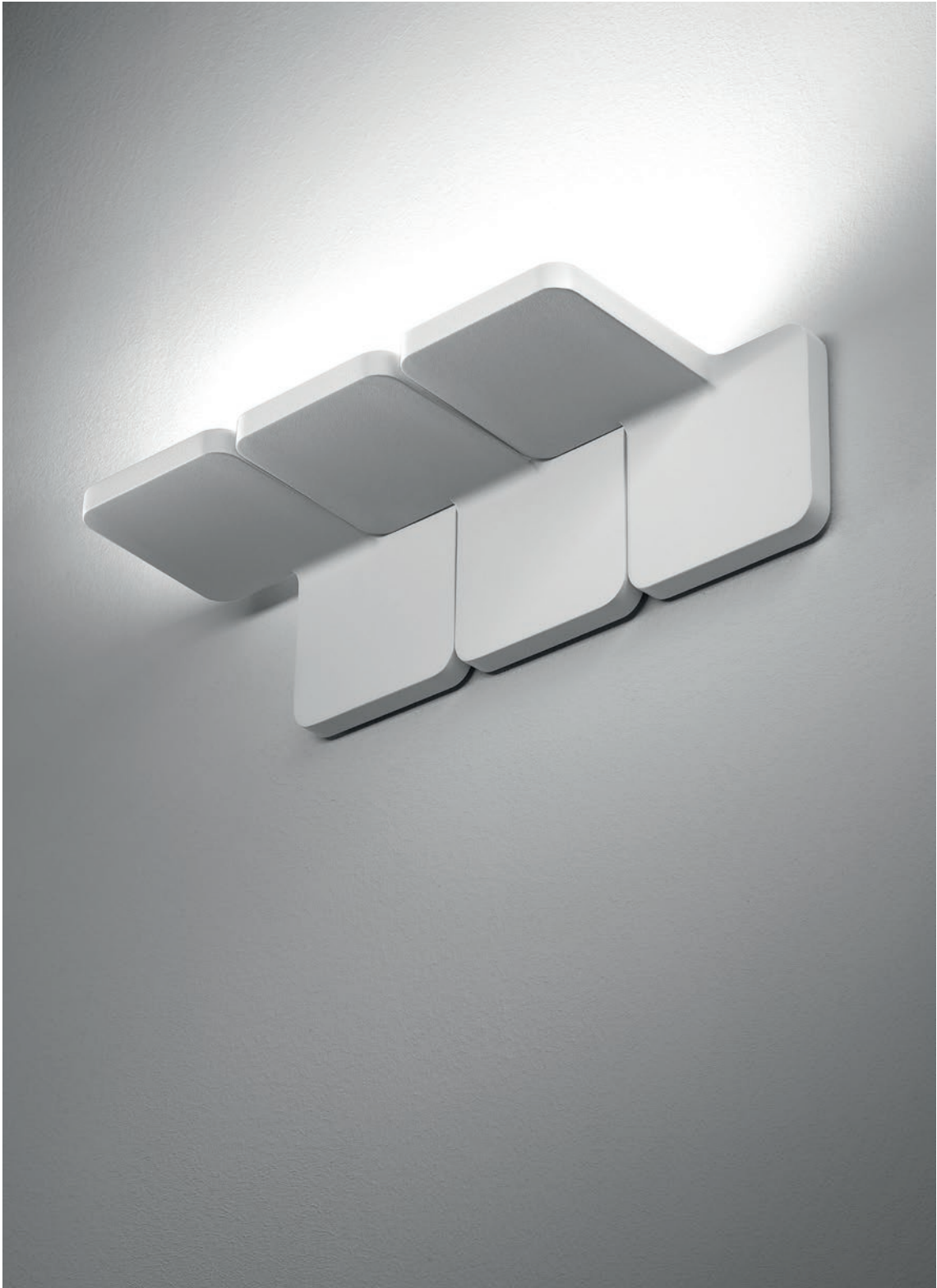



358

360

Quad_P







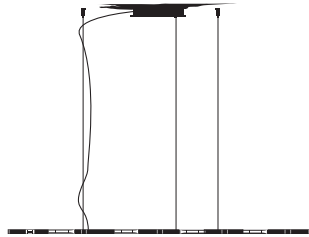

Technical Info

Quad_P1 | Pendant luminaires | 220-240 V | topLED 42 W

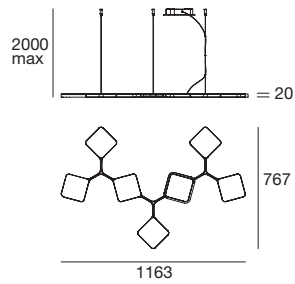

type

White	CRI 90	8114
Black	CRI 90	8115

colour

3000 K 4173 lm

optics

diffused

Quad_P2 | Pendant luminaires | 220-240 V | topLED 91 W

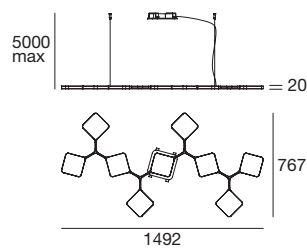

type

White	CRI 90	8110
Black	CRI 90	8111

colour

3000 K 9160 lm

optics

diffused

Quad_P3 | Pendant luminaires | 220-240 V | topLED 91 W

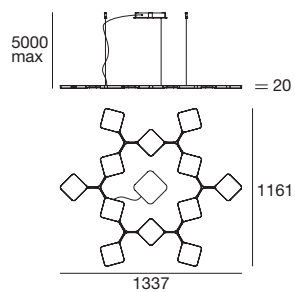

type

White	CRI 90	8112
Black	CRI 90	8113

colour

3000 K 9160 lm

optics

diffused

Quad_W | Wall light | topLED 19 W

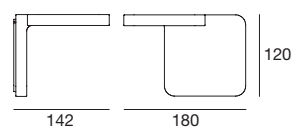

type

White	CRI 90	7750
Black	CRI 90	7753

colour

3000 K 1530 lm

optics

diffused

accessories



KIT0026

Dimmer

.Quad

.Quad is a module that can be assembled and combined like the alphabet.

What does an alphabet consist of?

It is made up of different letters that can be combined to form an utterance.

Quad is somewhat the same.

cit. Pio e Tito Toso





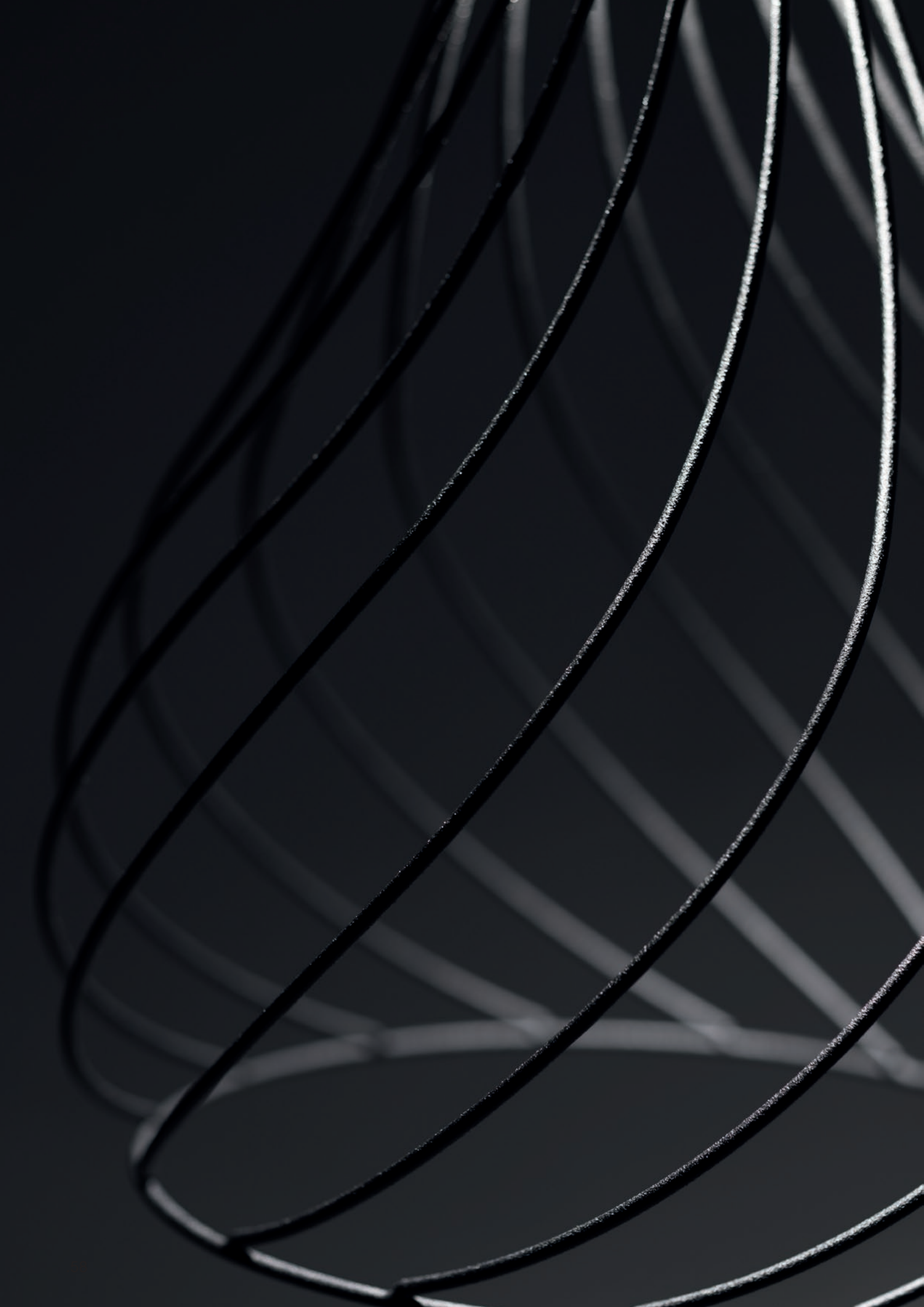

Refined lightness wrapping lines.

Organic self-wrapped structure, in two shapes: one, more open and airy, the other streamlined. A name evoking visual lightness. Suitable in varnished iron with copper or black finish. Designed to light a dinner table or the living, its vintage recall is perfect to create the right atmosphere in a restaurant or in a bistrot. Thanks to the LED Warm Tune™ dimmable technology the light spreads from source, varying intensity and color temperature simultaneously, following all the interior designer's needs

.Mongolfier

design Linea Light Group, 2016





Warm Tune™_Technology

Change the light, change the mood!

Traditional light

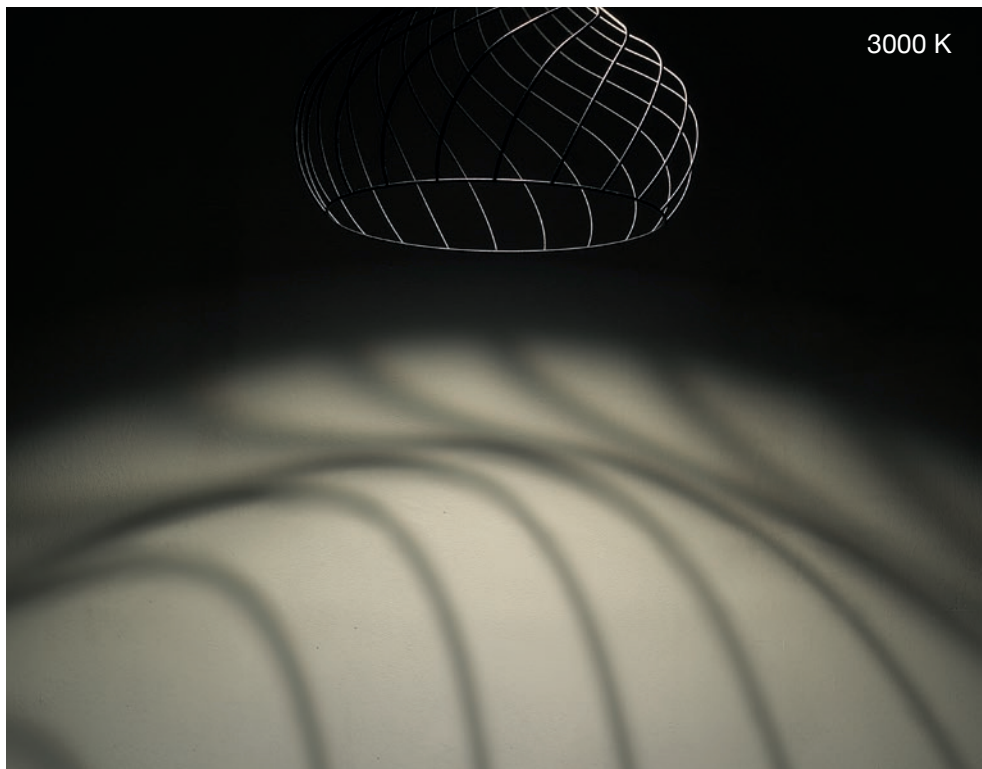

@ 100%



Relaxing light

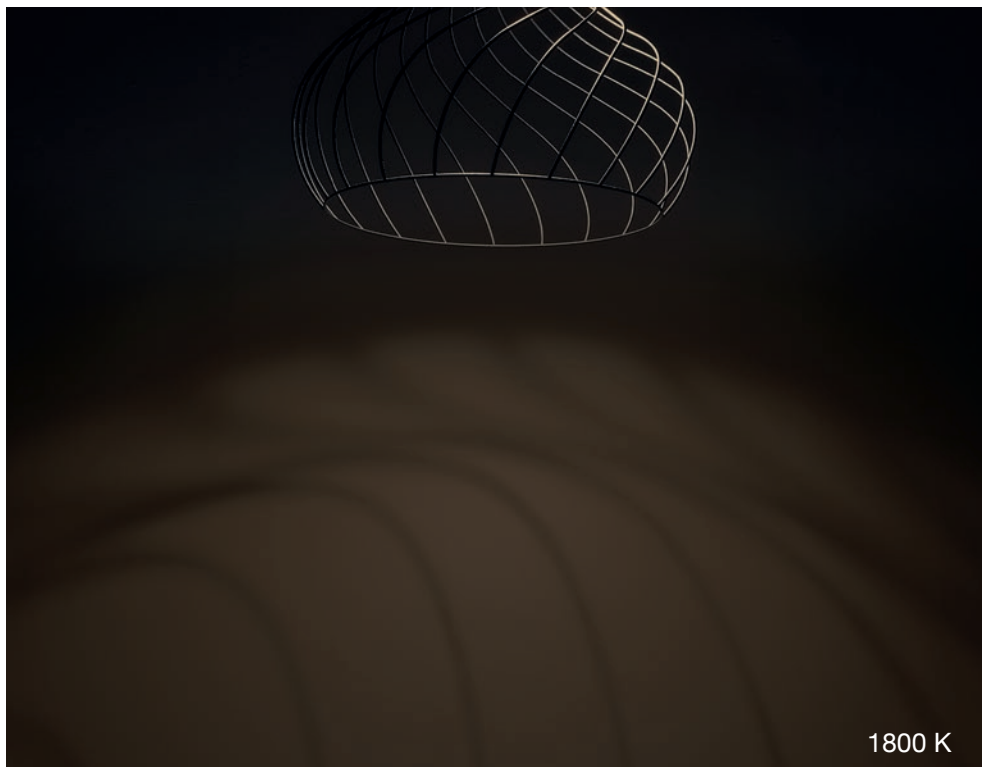

@ 5%



Technical Info

Mongolfier_P1 | Pendant luminaires | 220-240 V | 16 W

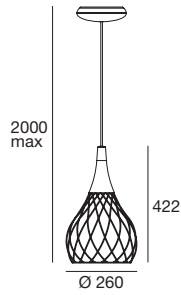

type

Black	CRI 90	8140
Copper	CRI 90	8141

colour

Warm Tune 845 lm

optics

diffused

accessories



KIT0026

Dimmer

Mongolfier_P2 | Pendant luminaires | 220-240 V | 16 W

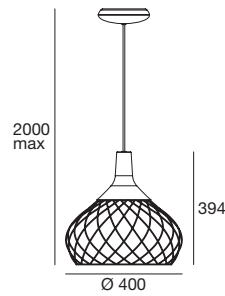

type

Black	CRI 90	8144
Copper	CRI 90	8145

colour

Warm Tune 845 lm

optics

diffused

accessories



KIT0026

Dimmer

cod. 8145

Mongolfier_P2

Pendant luminaires



.Mongolfier



.Emerging from the surrounding space,
sinuous stems interlace in
a light and airy design.

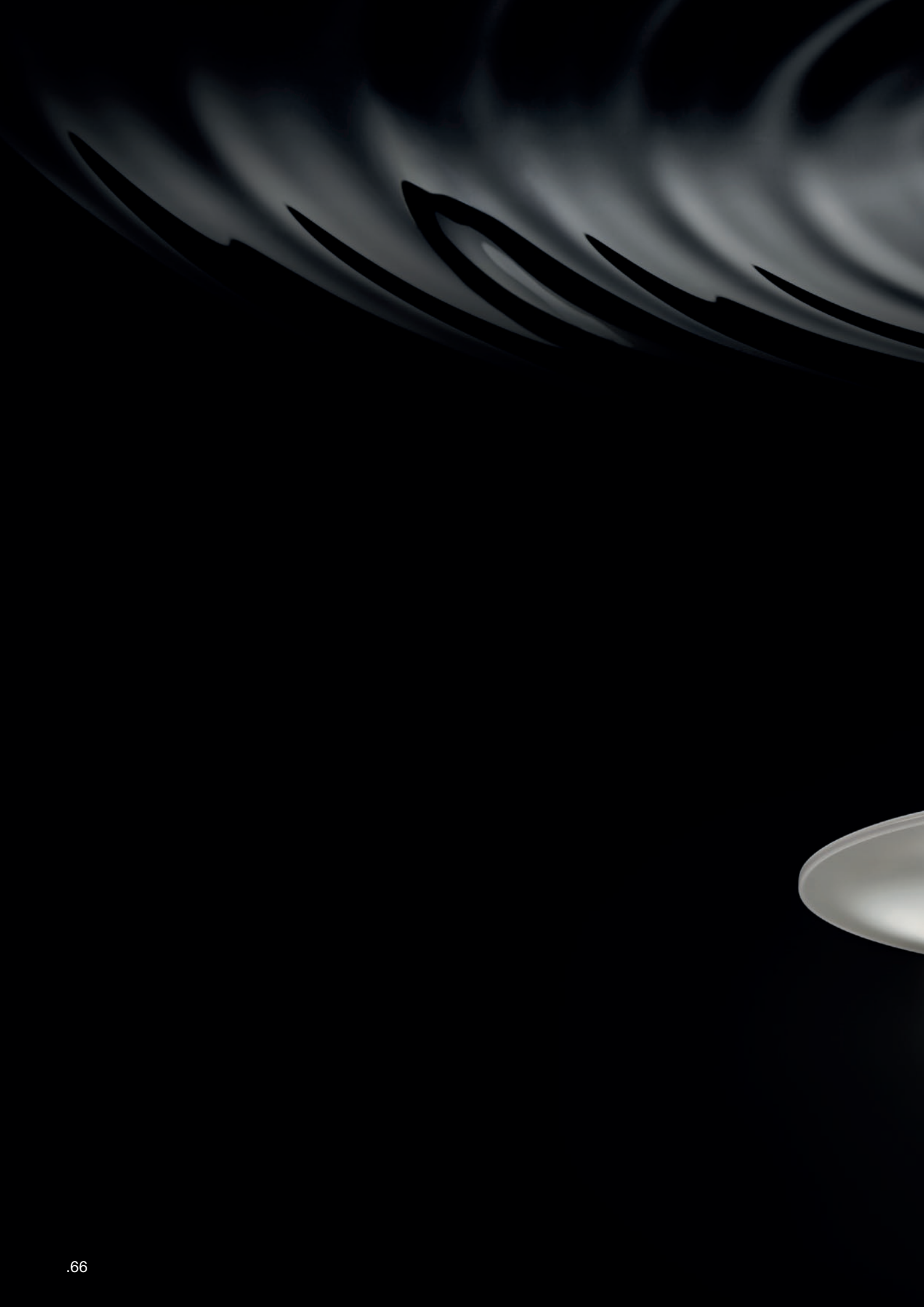





Light cloud. Waves rippling is frozen and turned into a lighting disc. Circle Wave was designed in two sizes and two typologies, suspension or ceiling. Aluminum case in matte white finish, double shell in PMMA thermoformed satin white finish. A transparency and shading mixture derives from a warm light LED source. Allowing a diffusive and smooth lighting. Perfect to illuminate high level private residences, hotel or open space

.Circle Wave

design Linea Light Group, 2012

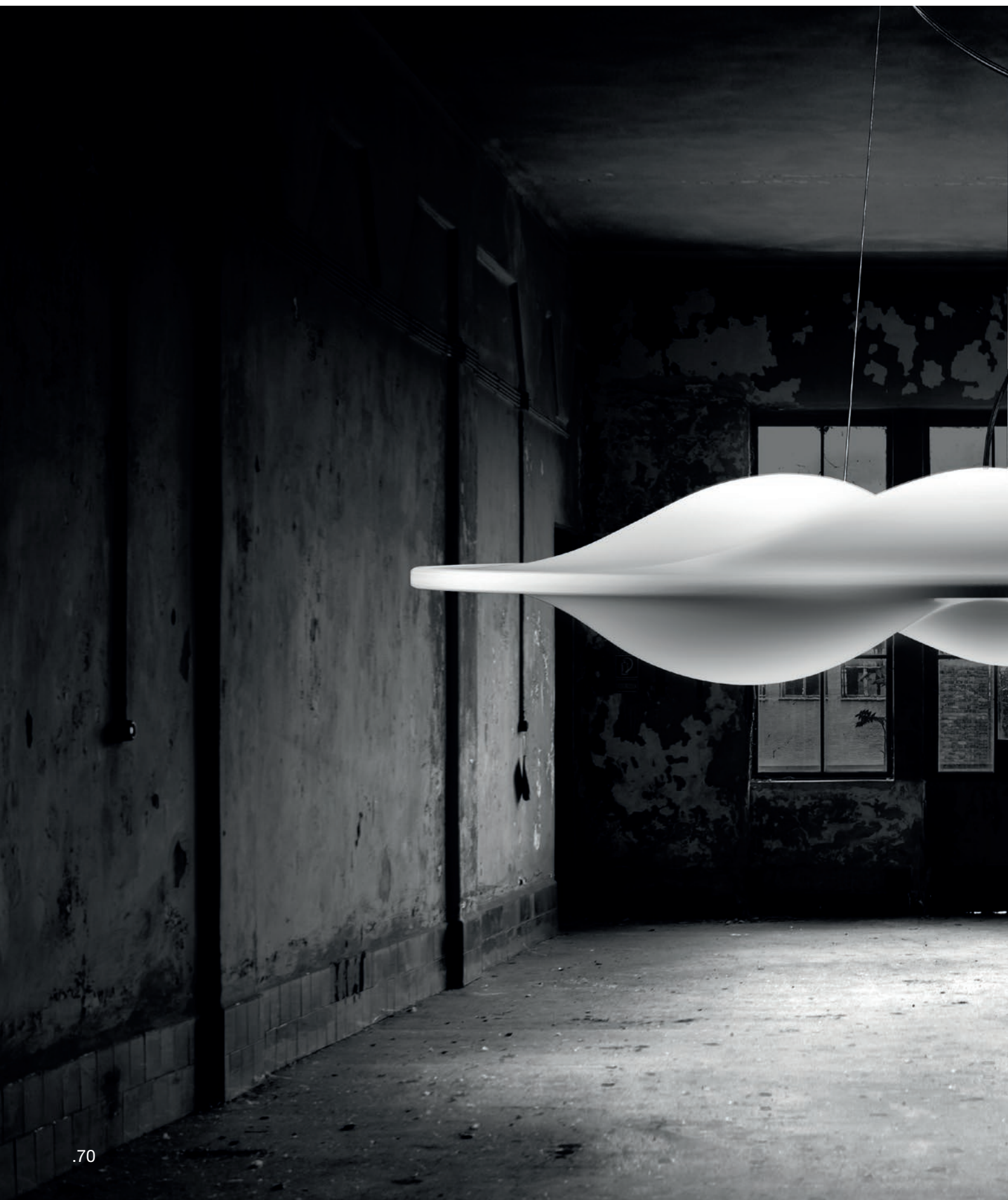

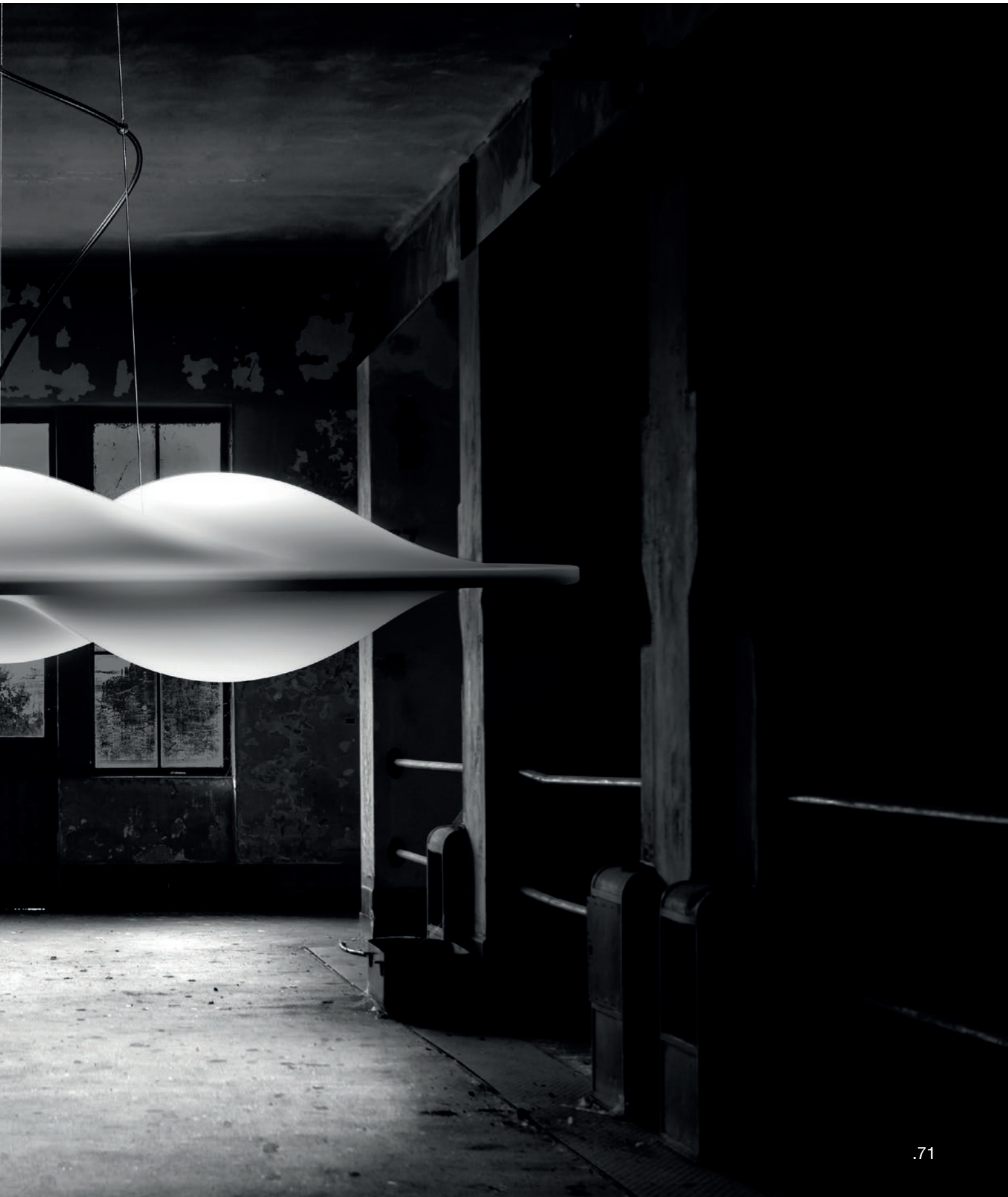

Circle Wave_P







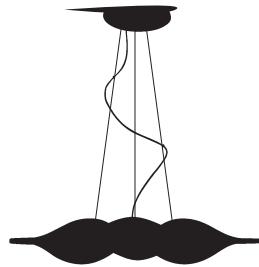

Technical Info

Circle Wave_P | Pendant luminaires | 220-240 V | topLED 28 W

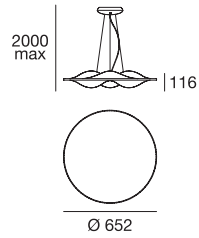

type

White CRI 90 **7462**

colour

3000 K 3442 lm

optics

diffused

Circle Wave_P | Pendant luminaires | 220-240 V | topLED 42 W

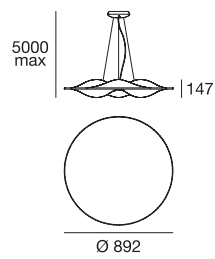

type

White CRI 90 **7460**

colour

3000 K 5010 lm

optics

diffused

Circle Wave_S | Ceiling luminaires | 220-240 V | topLED 28 W

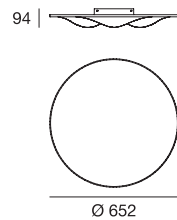

type

White CRI 90 **7463**

colour

3000 K 3243 lm

optics

diffused

Circle Wave_S | Ceiling luminaires | 220-240 V | topLED 42 W

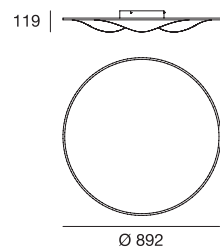

type

White CRI 90 **7461**

colour

3000 K 4864 lm

optics

diffused

.Circle Wave



.Inspired by Antoni Gaudí
and the organic shapes
evoking female curves and animal
creatures adorning the vaults
of Casa Batllò in Barcelona.





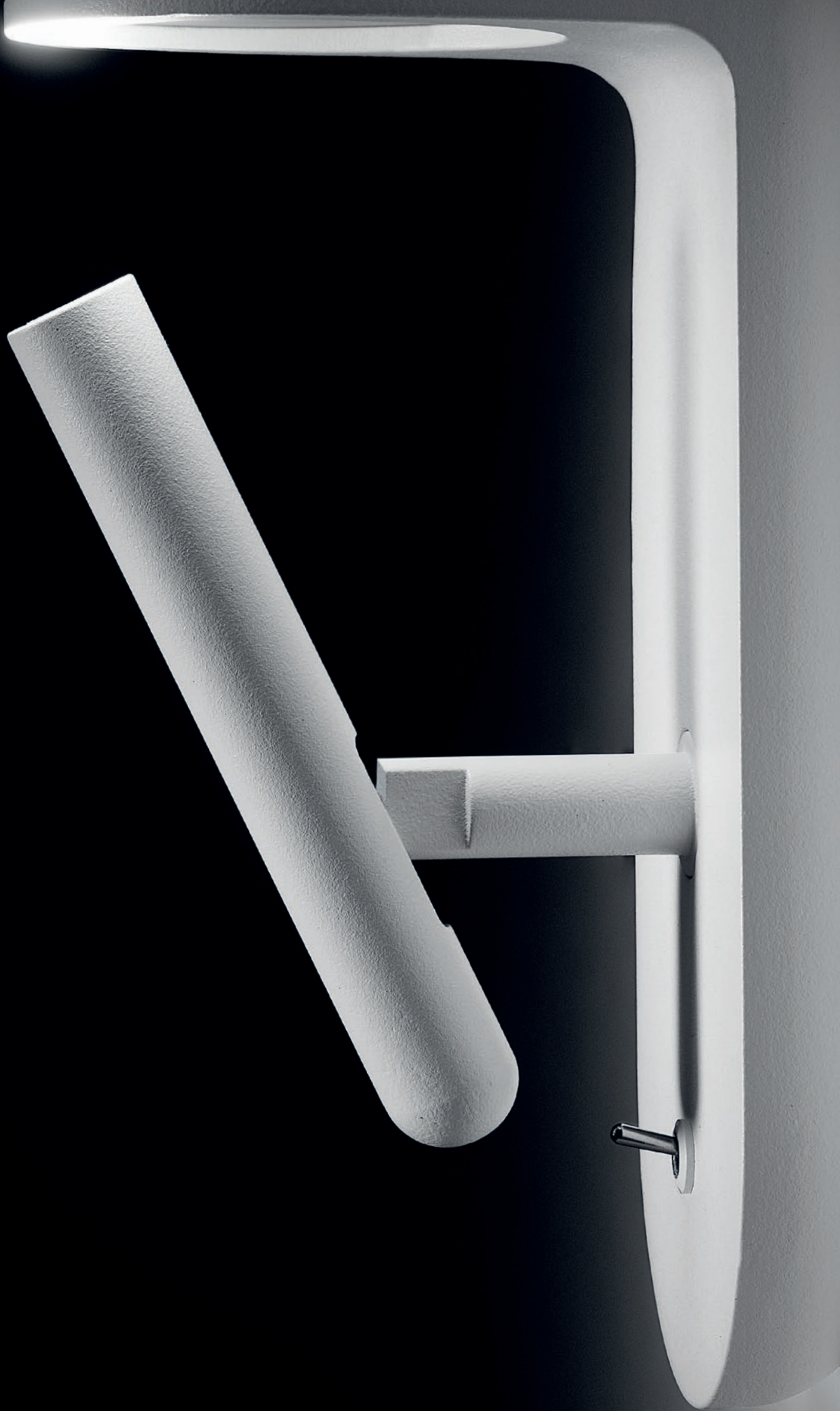

Eclectic light with versatile technology.

The Swiss designer Davide Oppizzi create this tiny precious lamp. Entirely in aluminum, its name reminds a double functionality and it can be fixed on headboard or on wall. LED source is placed in a movable, turning and adjustable aluminum cylinder with transparent polycarbonate diffuser. The thin wall structure has a superior opening containing a colored filter or a gobo, with special textures recalling water, fire or branches, projecting kaleidoscopic lighting games on wall

.2Nights

design Davide Oppizzi, 2016



reddot award 2016
winner

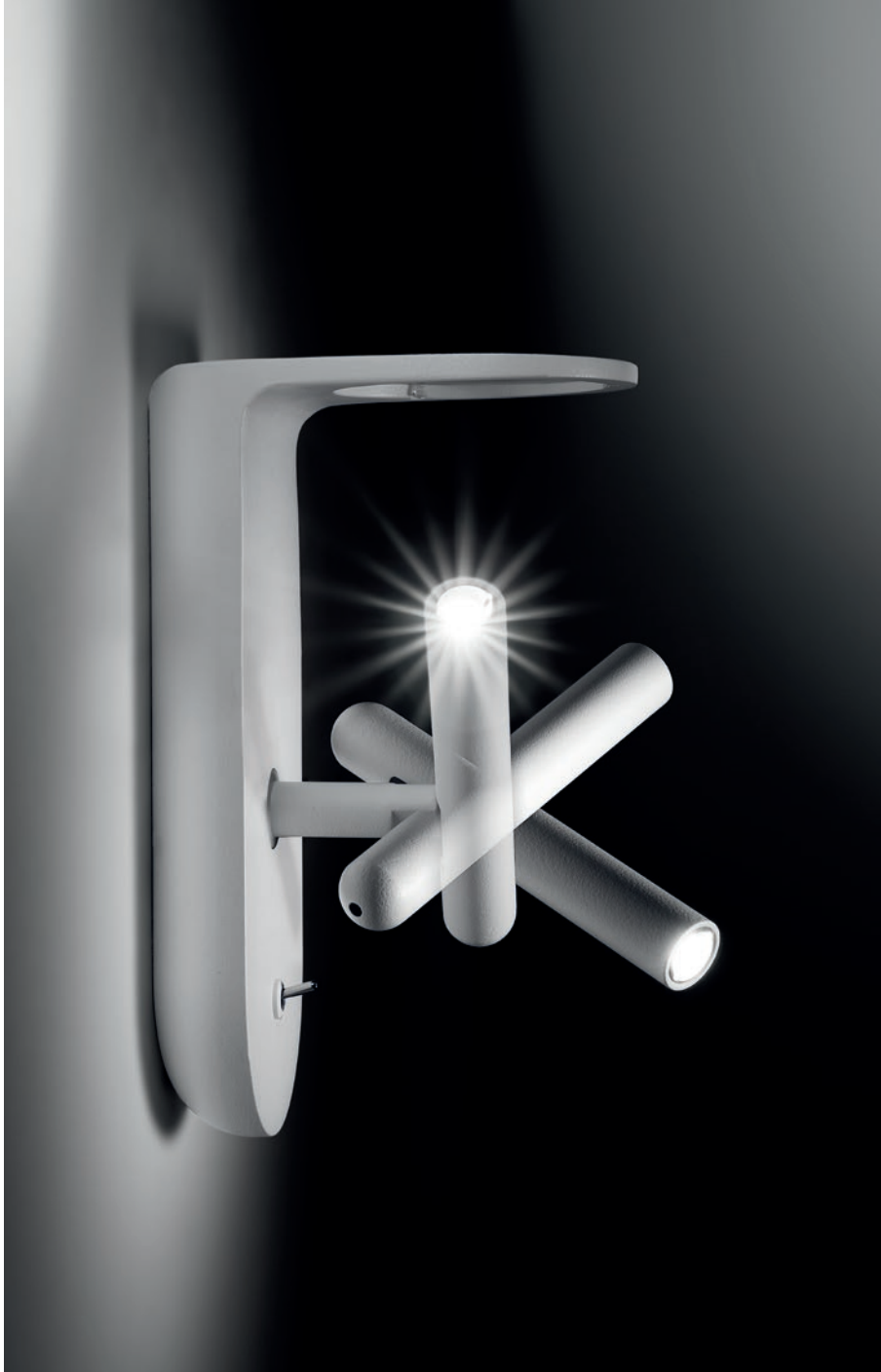







Technical Info

2Nights_W1 | Wall light | 220-240 V | topLED 4 W

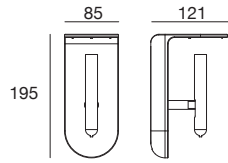

type

Wh.	Wh.	CRI 90	7975
Bl.	Bl.	CRI 90	7977
Wh.	Co.	CRI 90	7942
Bl.	Go.	CRI 90	7944

colour

3000 K 363 lm

optics

70°

accessories



included
filters



KIT0035
gobo filter Fire



KIT0055
gobo filter Tree



KIT0057
gobo filter Water

2Nights_W2 | Wall light | 220-240 V | topLED 4 W | integrated ON/OFF switch

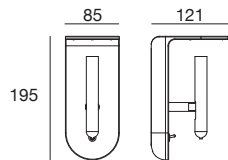

type

Wh.	Wh.	CRI 90	7976
Bl.	Bl.	CRI 90	7978
Wh.	Co.	CRI 90	7943
Bl.	Go.	CRI 90	7945

colour

3000 K 363 lm

optics

70°

accessories



included
filters



KIT0035
gobo filter Fire



KIT0055
gobo filter Tree



KIT0057
gobo filter Water



cod. 7944_7945

2Nights
Wall Light



2Nights | gobo filter Fire



type

White	KIT0035
Black	KIT0036

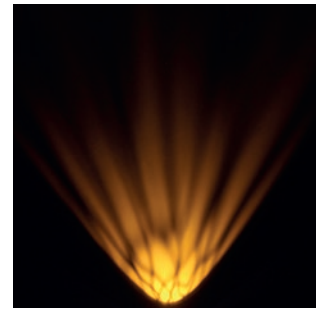

2Nights | gobo filter Tree



type

White	KIT0055
Black	KIT0056

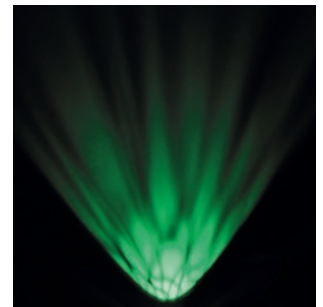

2Nights | gobo filter Water



type

White	KIT0057
Black	KIT0058

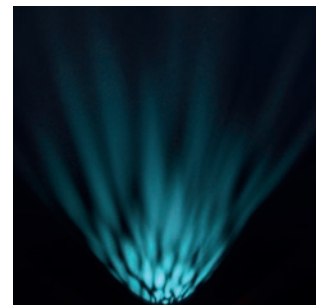

2Nights | coloured, transparent and opal filters



type

Amber	included
Opaque	included
Transp.	included

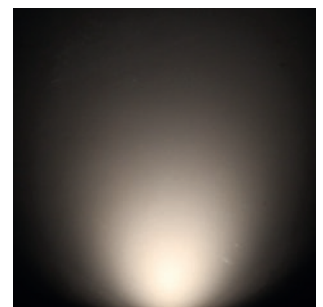



.2Nights

.During my many journeys,
hardly ever have I found a
multi-faceted versatile product that
could illuminate a book while you
are lying on your bed and lend a
relaxed atmosphere to the room.
Not the shape, rather,
the functionality of the object:
2nights was conceived
bearing this in mind.

cit. Davide Oppizzi

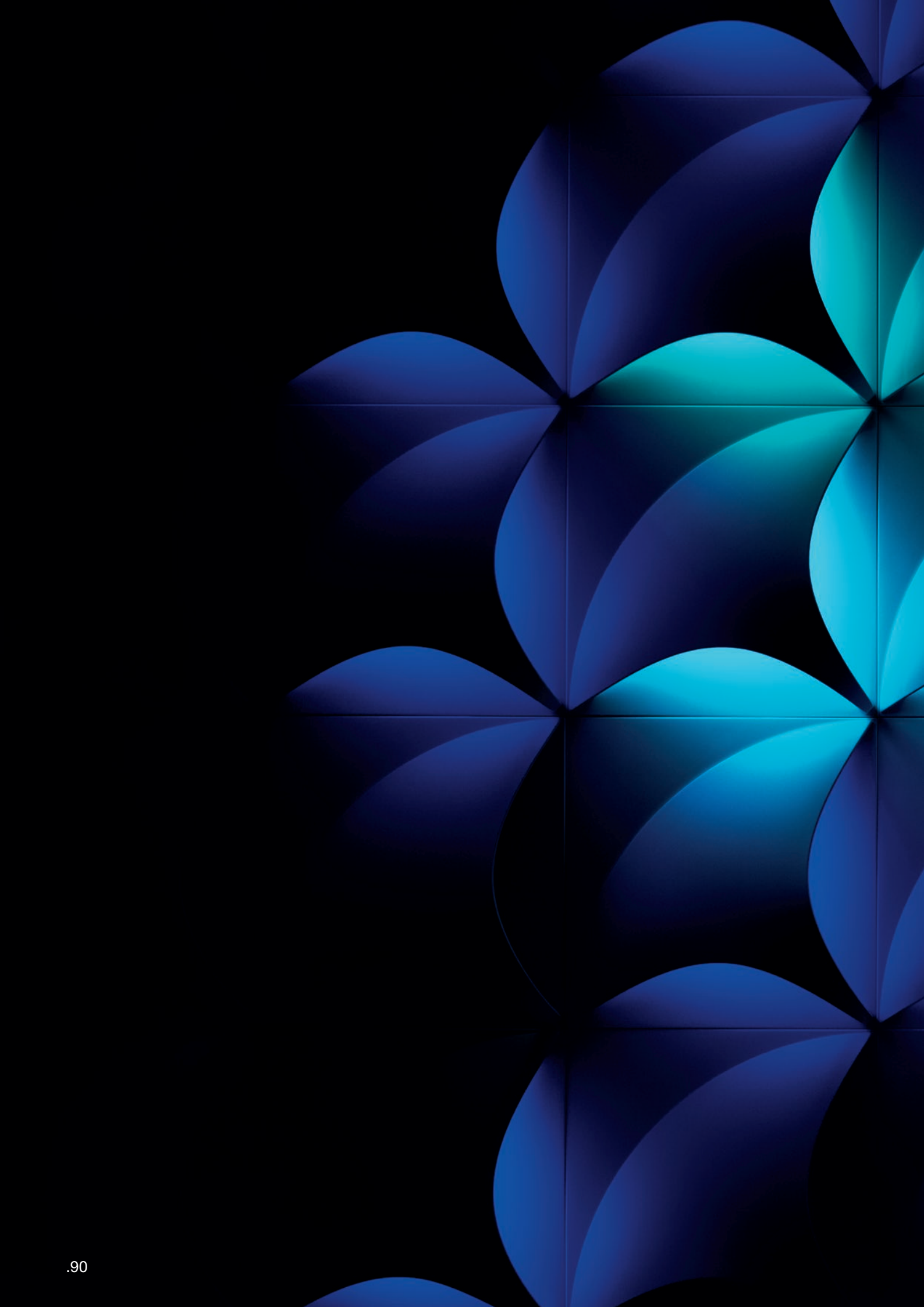

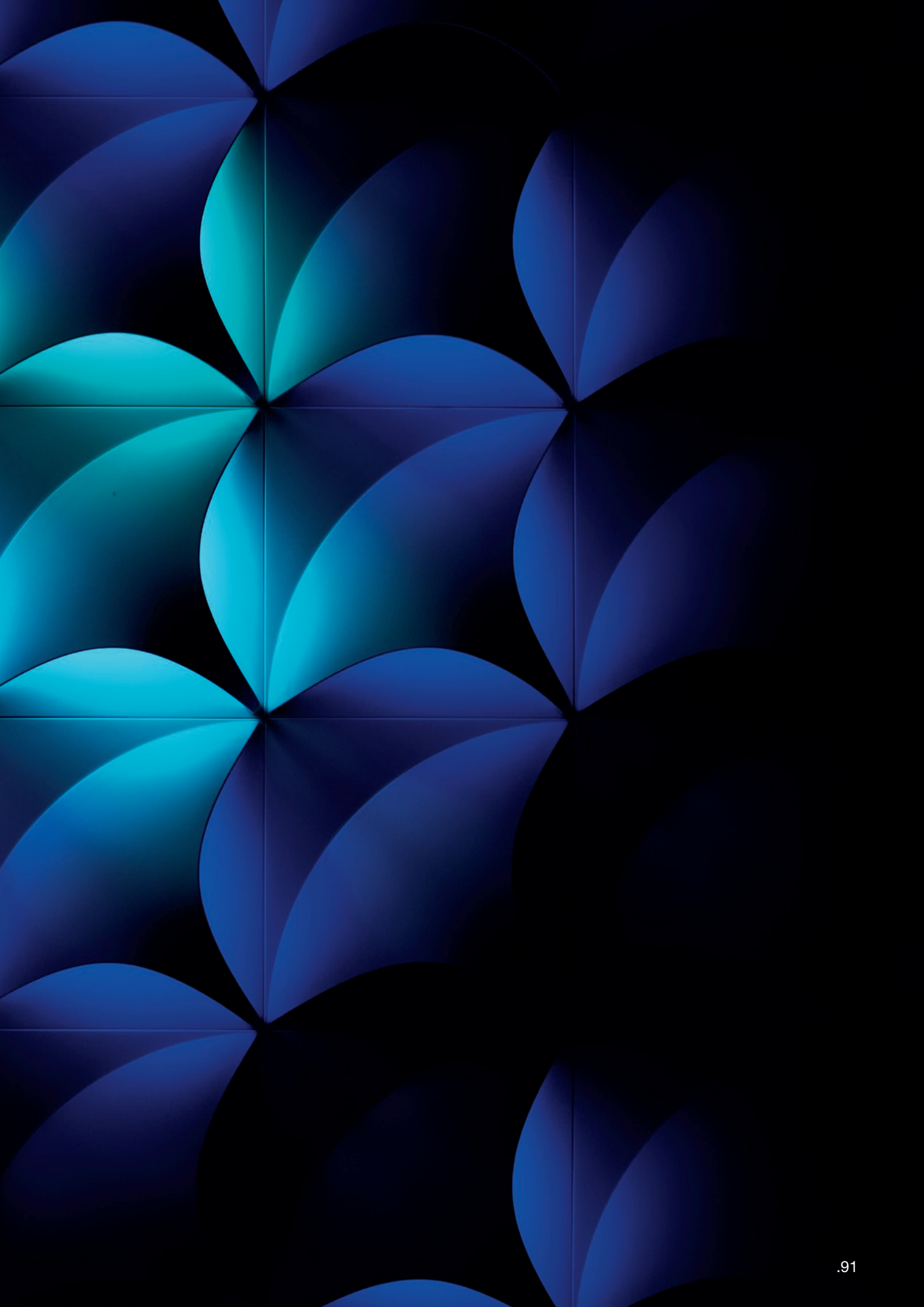

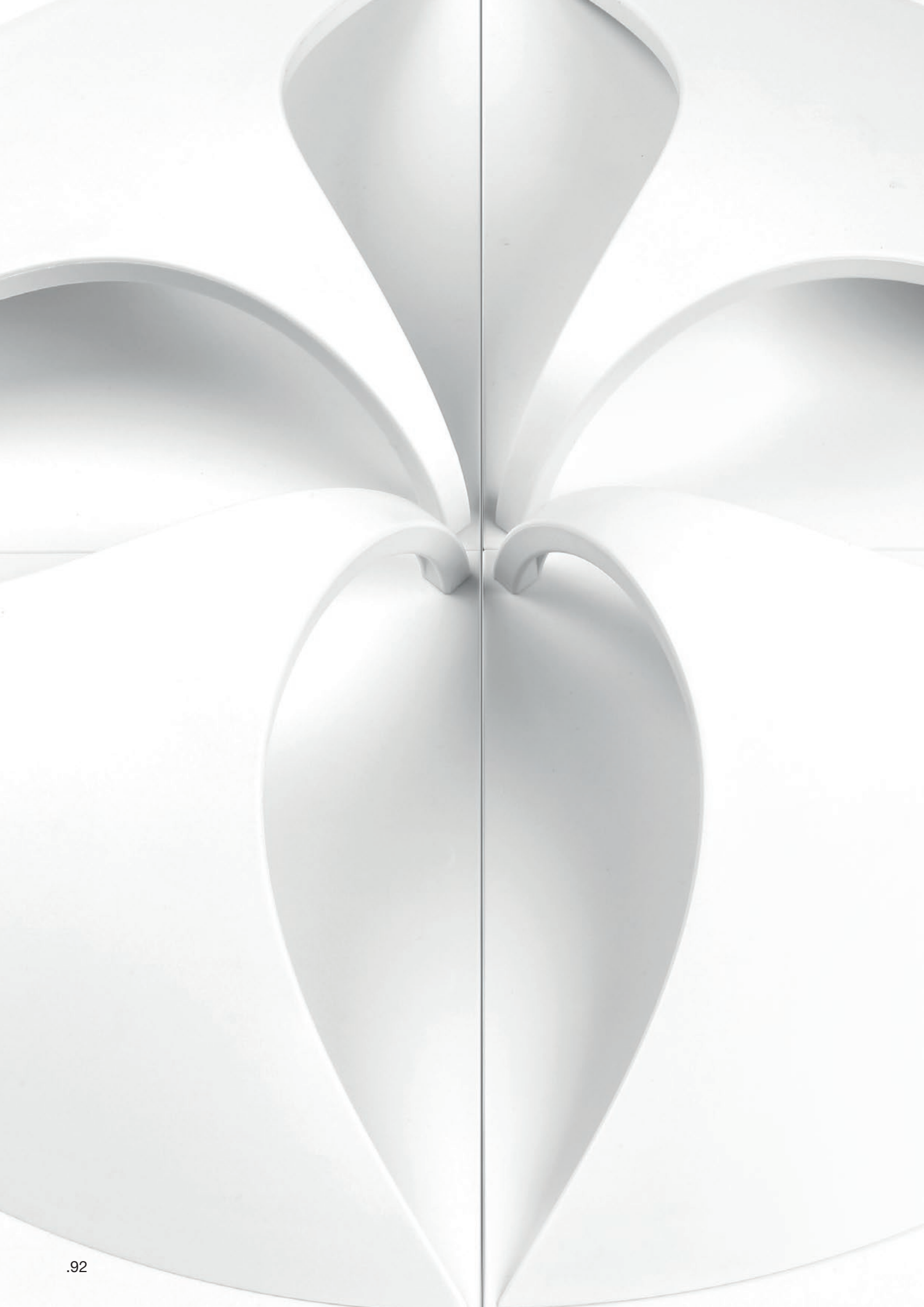

Vertical colored light gardens.

Ceramist Colin Johnson designed Moonflower, a LED wall created to furnish with lights, playing with colors and giving dynamicity to living space. Modular and freely composable, the ABS vault allows precious reflections games, an unusual lighting diffusion, always original. Its peculiar diffuser shape evokes vertical gardens suggestive compositions. The DMX controller regulates and drives different programs, static or dynamic, predefined or custom, total freedom. An adaptive unique light decoration

.Moonflower

design Colin Johnson, 2014





Moonflower

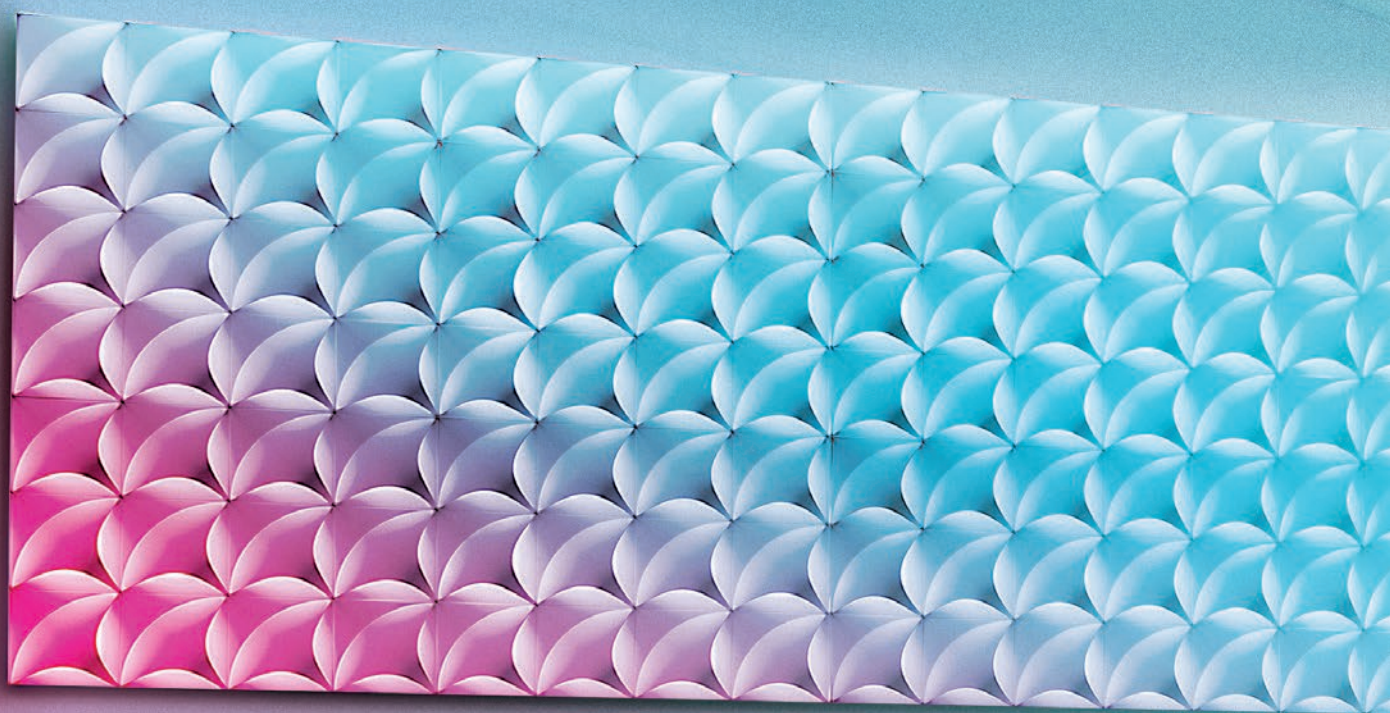

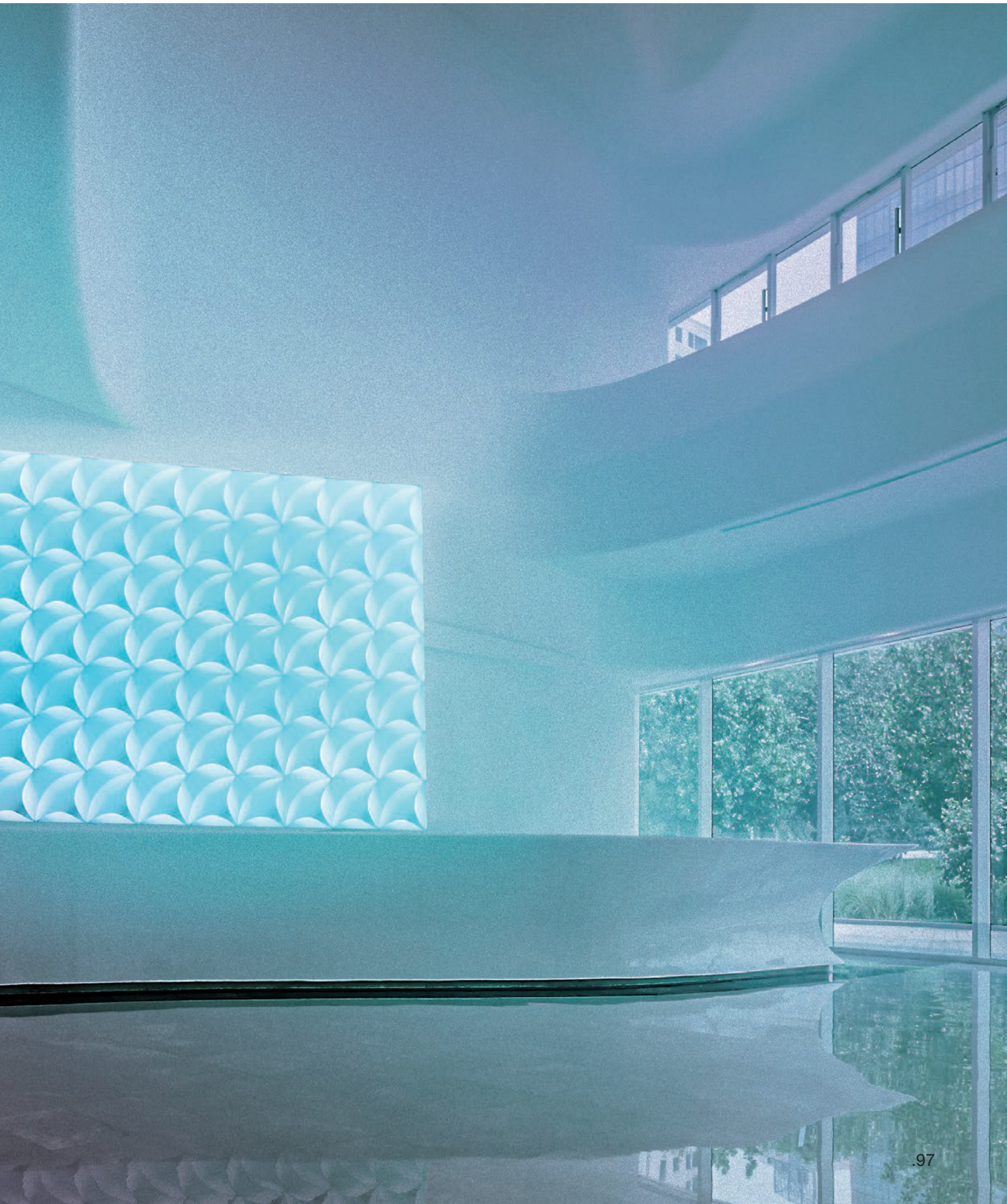

Moonflower

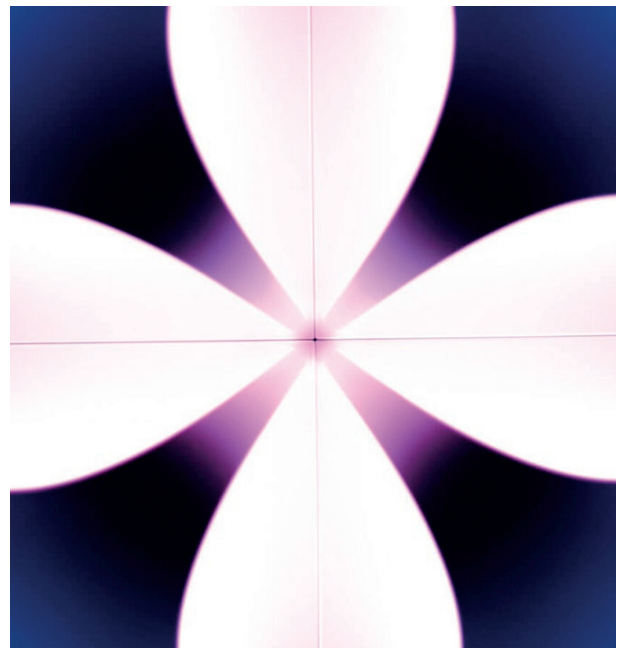
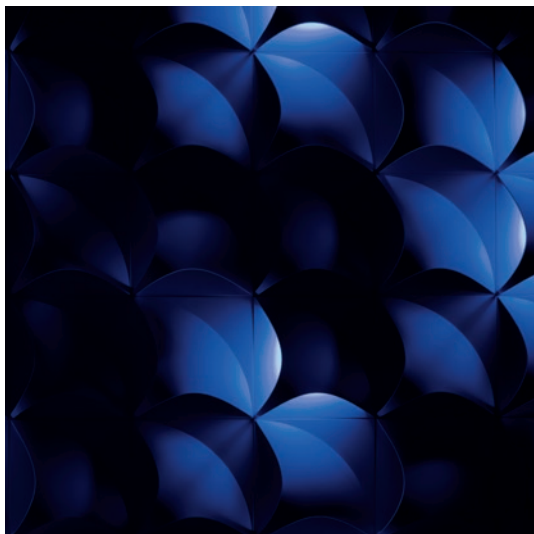
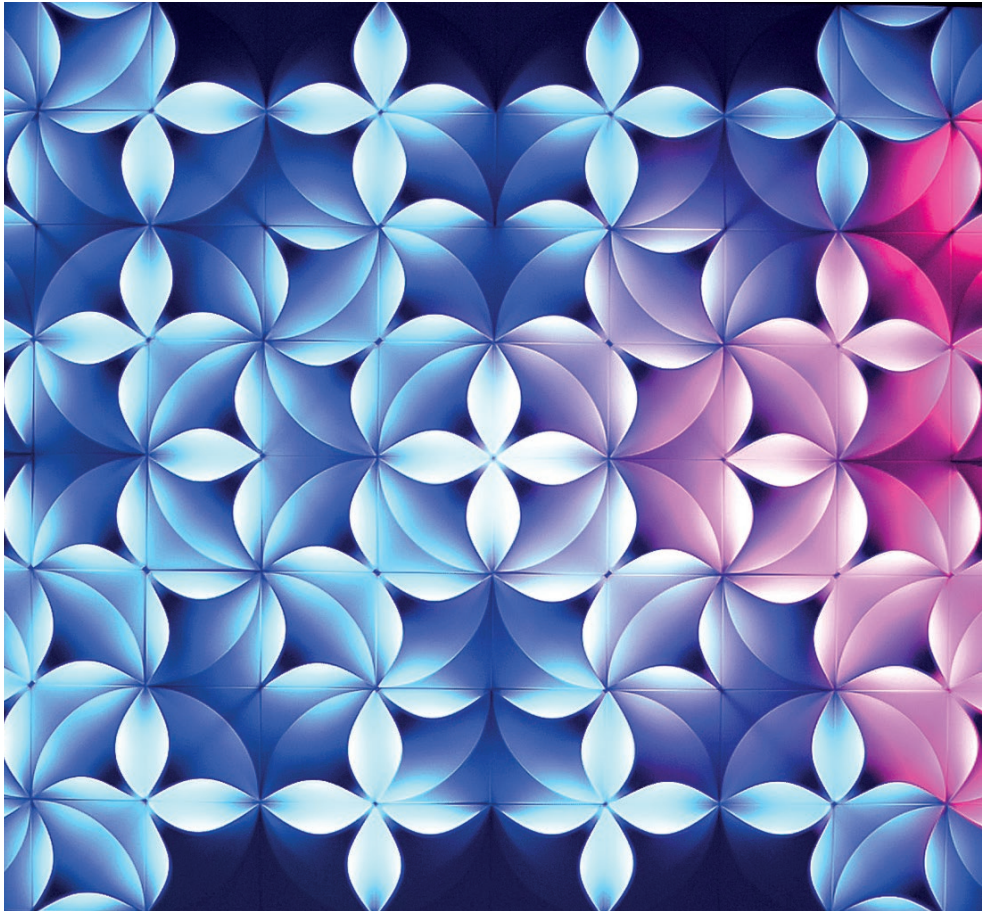

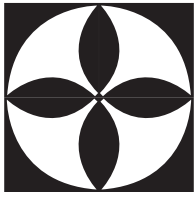

Technical Info

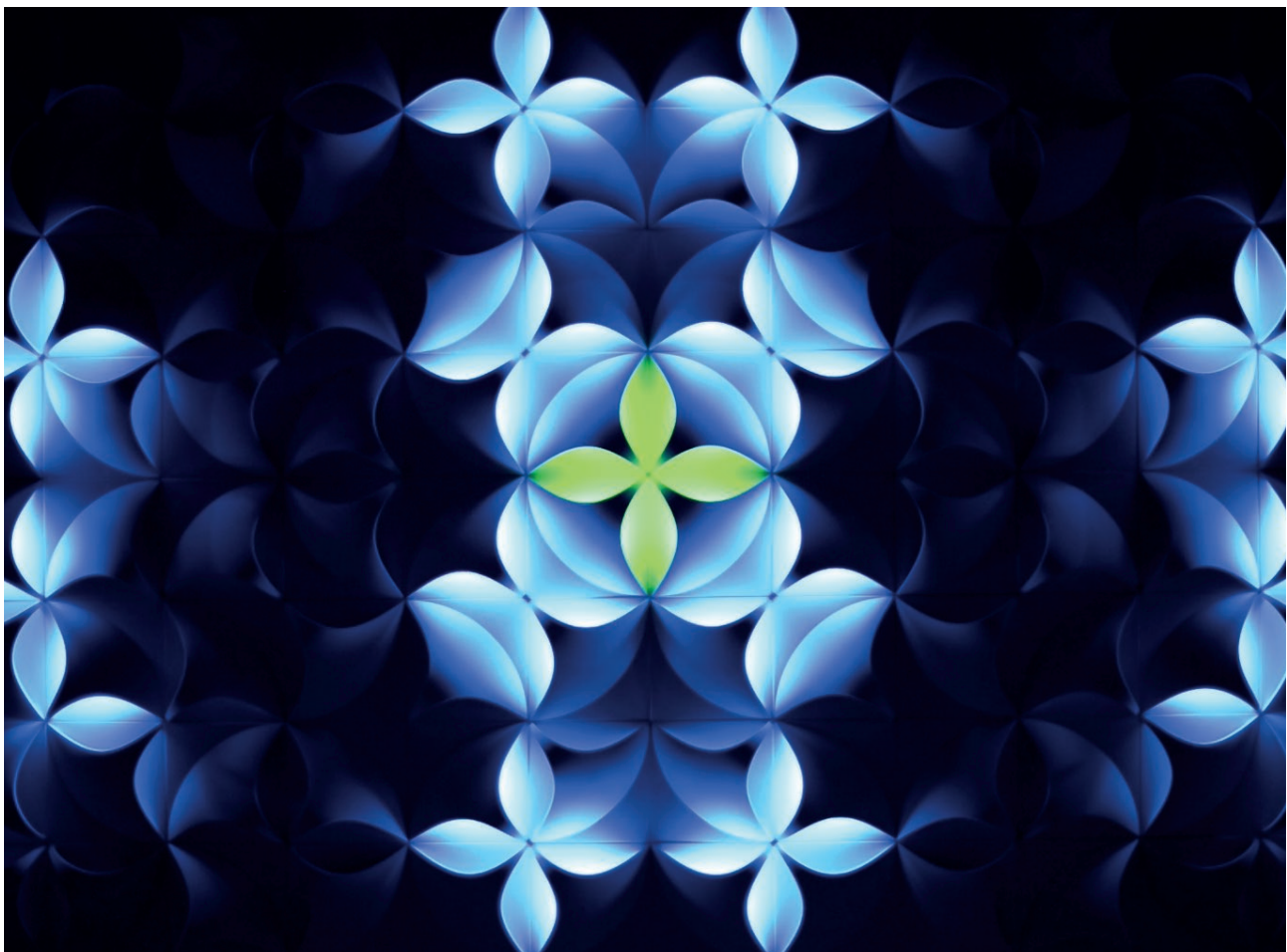
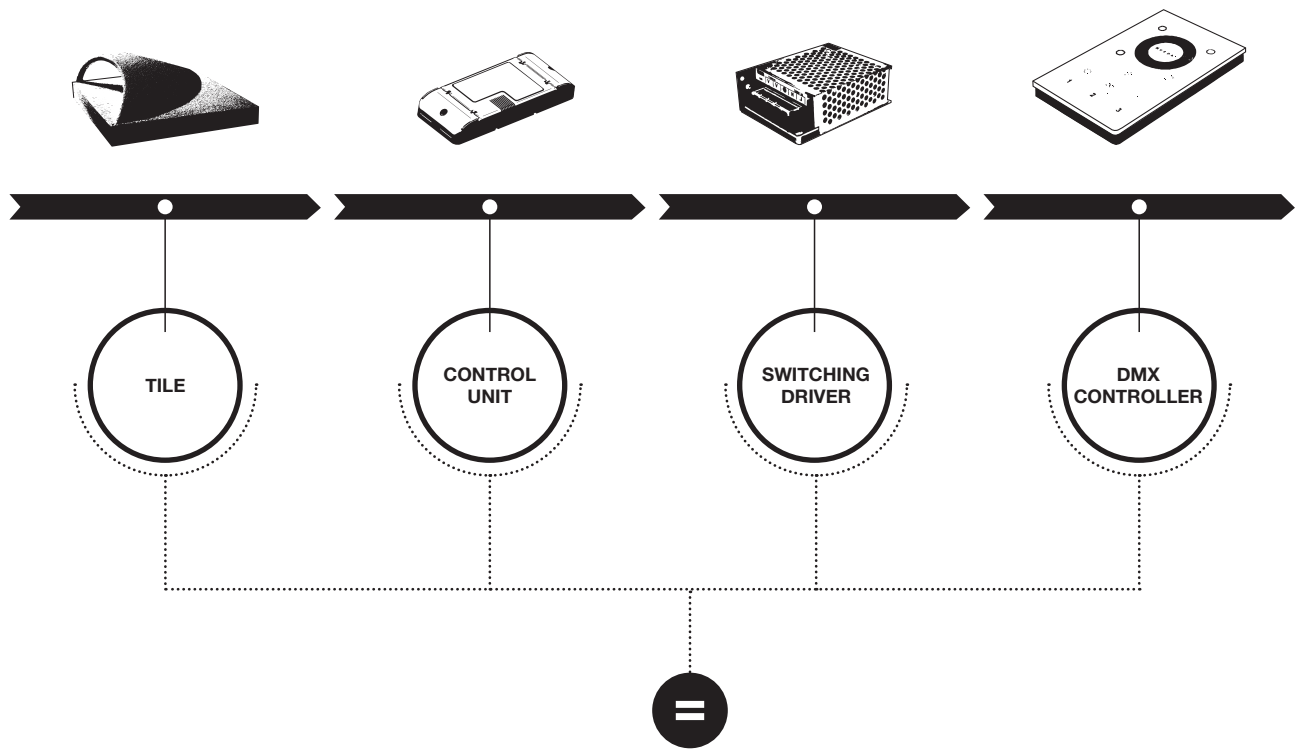

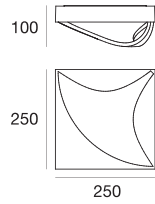

type

White 7760

colour

RGB

optics

diffused

accessories



KIT0048
Fixing bracket



KIT0049
Power Cable
2x0,35 mm²
L= 600 mm.



KIT0050
RGB Signal
FLAT Cable
6x0,08 mm²
L= 320 mm.

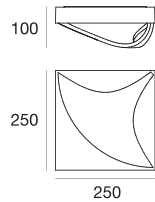

type

White 7761

accessories



KIT0048
Fixing bracket



Videos, pictures, information and much more on the dedicated mini-website. Scan the QR code at the side to discover Moonflower extra content.

For DMX projects please contact the design department support@linealight.com

linealight.com/moonflower

Control Unit | Stand Alone / DMX RGB Driver | 24 V DC

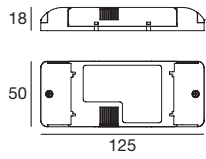

Management of 21 preset programmes (5 fade and 16 static backdrop) through NO buttons, in master/slave stand alone mode. Compatible with DMX 512 protocol to manage advanced backdrops.

range	output	input	PF	
Power 1ch x (1-60 LEDs/ch)	2,5A	24V DC	0,97	KIT0011
Signal 3+3ch x (1-1000 LEDs/ch)				

accessories



KIT0053
Cable for DMX signal wiring
DMX version
3x0,25 mm²
L= 1200 mm.



KIT0054
Cable for Controller wiring
Stand Alone version
2x0,5 mm²
L= 400 mm.

Driver | Switching Driver 220-240 V DC 20W

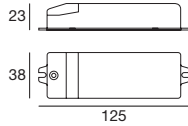

High efficiency and power factor. Self-restoring protection against open circuits and short circuits on the output line. Compatible with a maximum of 20 tiles (stand alone). When adding a DMX control unit, remove 2 tiles.

output	input	PF	
20W 24V	220~240V DC	0.90	KIT0019

accessories



KIT0052
Cable
2x1 mm²
L= 600 mm.



KIT0051
Splitter
4xM - 2xM connectors
24V 3A - 24V 6A in/out

Driver | Switching Driver 220-240 V DC 70W

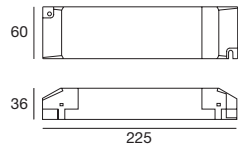

High efficiency and power factor. Self-restoring protection against open circuits and short circuits on the output line. Compatible with a maximum of 65 tiles (stand alone). When adding a DMX control unit, remove 2 tiles.

output	input	PF	
70W 24V	220~240V DC	0.97	KIT0020

accessories



KIT0052
Cable
2x1 mm²
L= 600 mm.



KIT0051
Splitter
4xM - 2xM connectors
24V 3A - 24V 6A in/out

Driver | Switching Driver 220-240 V DC 150W

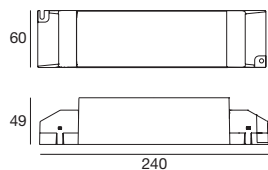

High efficiency and power factor. Self-restoring protection against open circuits and short circuits on the output line. Compatible with a maximum of 130 tiles (stand alone). When adding a DMX control unit, remove 2 tiles.

output	input	PF	
150W 24V	220~240V DC	0.97	KIT0021

accessories



KIT0052
Cable
2x1 mm²
L= 600 mm.



KIT0051
Splitter
4xM - 2xM connectors
24V 3A - 24V 6A in/out

Stick_DE3 | DMX Controller

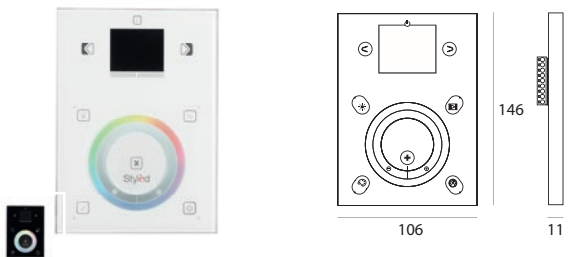

type	signal output	connector	input	
White	DMX	CLAMP RJ45 mini USB	5.5~6V DC	99234
Black	DMX	CLAMP RJ45 mini USB	5.5~6V DC	99235



Stick_GU2 | DMX Controller

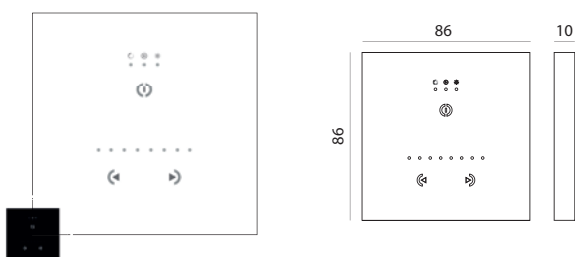
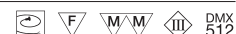

type	signal output	connector	input	
White	DMX	CLAMP micro USB	5.5~12V DC	99045
Black	DMX	CLAMP micro USB	5.5~6V DC	99046



Slesa_UE7 | DMX Controller

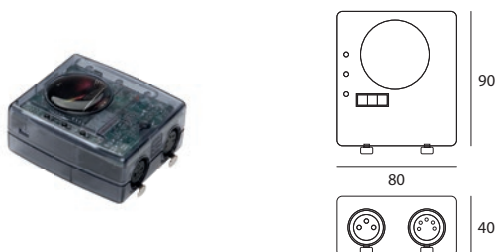

type	signal output	connector	input	
Black	DMX	RJ45 XLR 3 Pin F. XLR 5 Pin F. mini USB	5.5~6V DC	99050



Maestro 1.0 | Consult Professional LED Lighting



For additional information on the abovementioned products, please refer to the pages on the technical catalogue Maestro 1.0 "Professional LED Lighting" 2016.

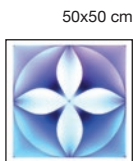
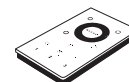

Stand Alone	4 x 7760 8 x KIT0048 3 x KIT0049 3 x KIT0050	1 x KIT0011 1 x KIT0054	1 x KIT0019 1 x KIT0052	
	4 x 7760 8 x KIT0048 3 x KIT0049 3 x KIT0050	1 x KIT0011 1 x KIT0053	1 x KIT0019 1 x KIT0052	99234 99235 1 x 99045 99046 99050

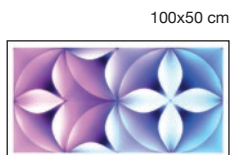

Stand Alone	8 x 7760 20 x KIT0048 7 x KIT0049 7 x KIT0050	1 x KIT0011 1 x KIT0054	1 x KIT0019 1 x KIT0052	
	8 x 7760 20 x KIT0048 7 x KIT0049 7 x KIT0050	4 x KIT0011 3 x KIT0053	1 x KIT0019 2 x KIT0051 2 x KIT0052	99234 99235 1 x 99045 99046 99050



Stand Alone	24 x 7760 76 x KIT0048 23 x KIT0049 23 x KIT0050	1 x KIT0011 1 x KIT0054	2 x KIT0019 1 x KIT0051 1 x KIT0052	
	24 x 7760 76 x KIT0048 23 x KIT0049 23 x KIT0050	12 x KIT0011 11 x KIT0053	2 x KIT0020 6 x KIT0051 6 x KIT0052	99234 99235 1 x 99045 99046 99050

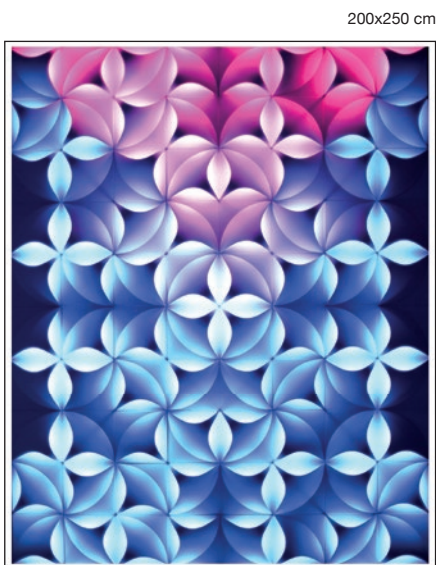

Stand Alone	80 x 7760 284 x KIT0048 79 x KIT0049 79 x KIT0050	1 x KIT0011 1 x KIT0054	1 x KIT0021 3 x KIT0051 3 x KIT0052	
	80 x 7760 284 x KIT0048 79 x KIT0049 79 x KIT0050	40 x KIT0011 39 x KIT0053	2 x KIT0021 20 x KIT0051 20 x KIT0052	99234 99235 1 x 99045 99046 99050

.Moonflower

.I wanted to create a piece
where there was an interplay
between light and form,
where the light changes the way we
perceive the form and where the
form provides a narrative wherein
the dance of light can take place.

cit. Colin Johnson

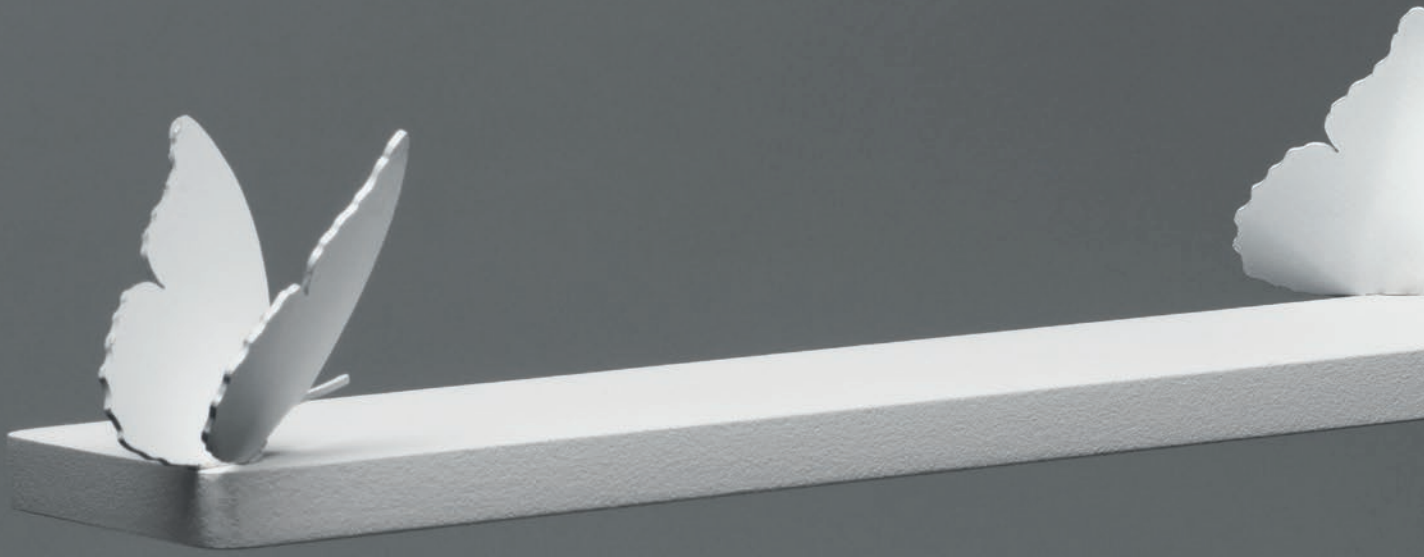

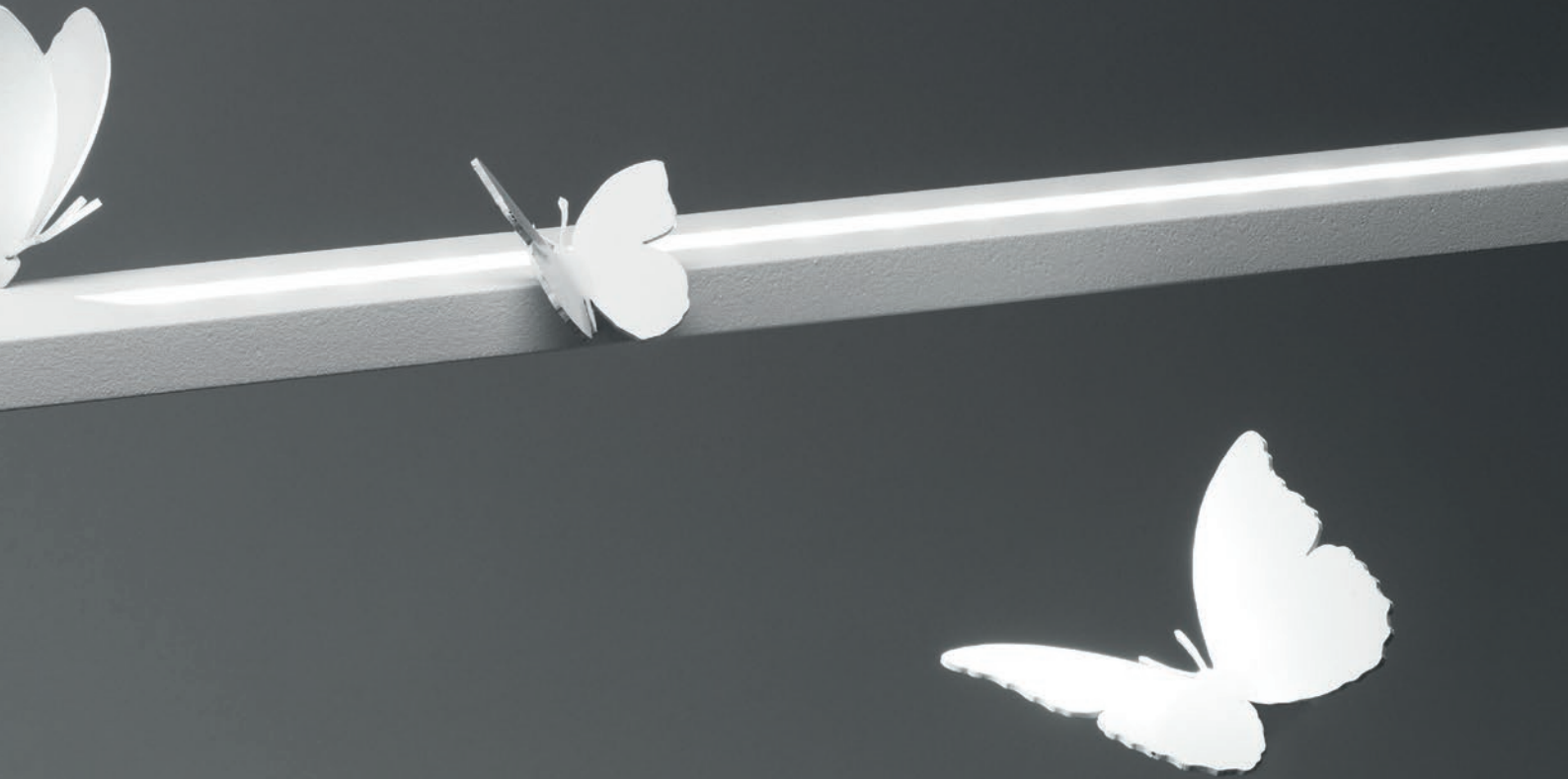



Technological light and shape

synthesis. Lama has a thin profile, synthesis between technology and minimalism. Its peculiar shape and double light emission smooth contrasts and marked shadows. Aluminum body with opal polycarbonate diffuser, it is available in different versions, for every designer needs: floor, wall, table, perfect to light up desks and tables, or suspension. Suitable to light open space or hotel. The Office floor version is perfect for lighting spaces with computers, requesting a determined and very high comfortable lighting

.Lama

design Linea Light Group, 2011



reddot design award
winner 2011

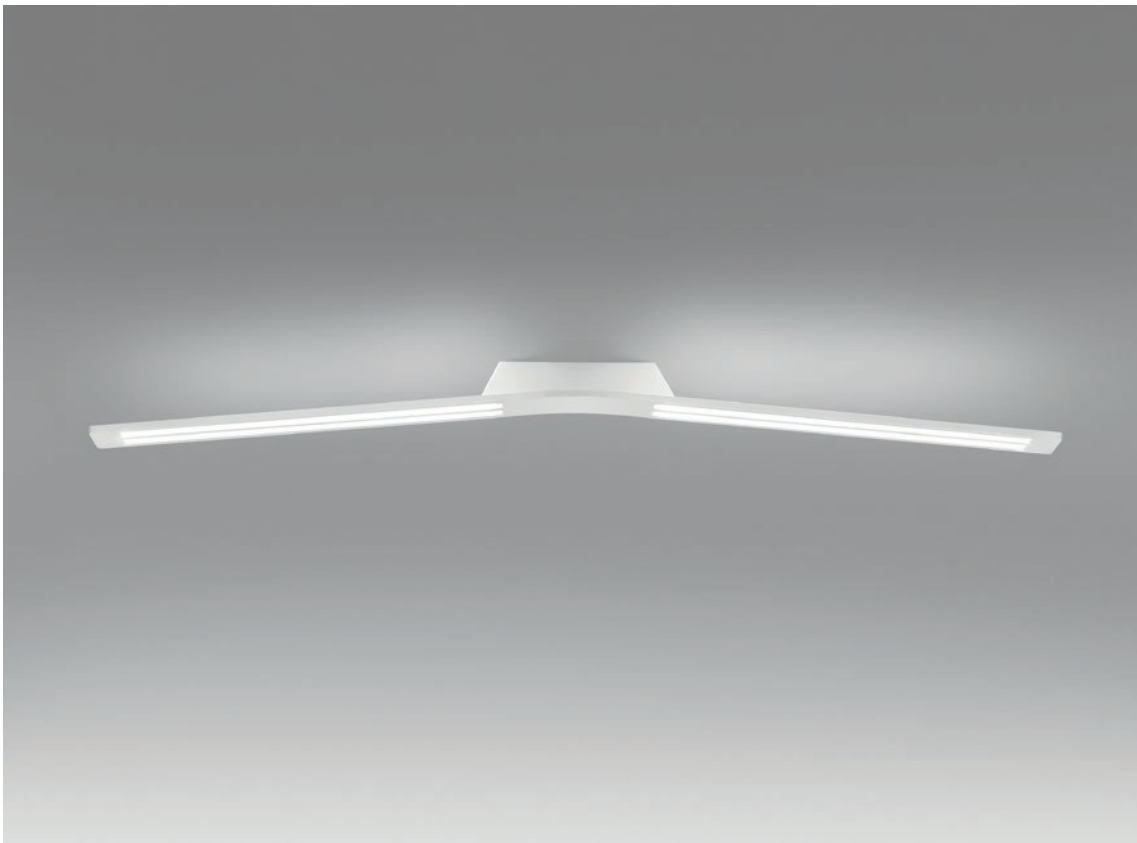











Technical Info

Lama_P1 | Pendant luminaires | 220-240 V | topLED 45 W

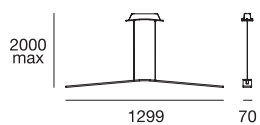

type

White	CRI 90	7106
Grey	CRI 90	7108

colour

3000 K 3241 lm

optics

diffused

Lama_P2 | Pendant luminaires | 220-240 V | topLED 48 W

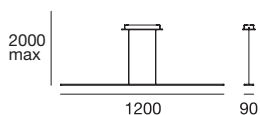

type

White	CRI 90	7118
Grey	CRI 90	7119

colour

3000 K 3450 lm

optics

diffused

cod. 7106
Lama_P1
Pendant luminaires



Lama_S | Ceiling luminaires | 220-240 V | topLED 45 W

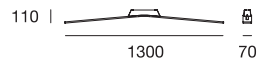

type

White	CRI 90	7109
Grey	CRI 90	7111

colour

3000 K 3241 lm

optics

diffused

Lama_W | Wall light | 220-240 V | topLED 21 W

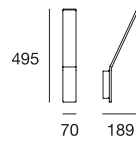

type

White	CRI 90	7104
Grey	CRI 90	7107

colour

3000 K 2505 lm

optics

diffused

cod. 7104
Lama_W
Wall Light



Lama_FL | Free standing | 220-240 V | topLED 26 W

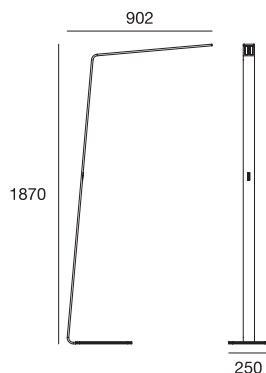

type

White	CRI 90	7100
Grey	CRI 90	7102

colour

3000 K 1870 lm

optics

diffused

Lama_FL office | Free standing | 220-240 V | topLED 38 W

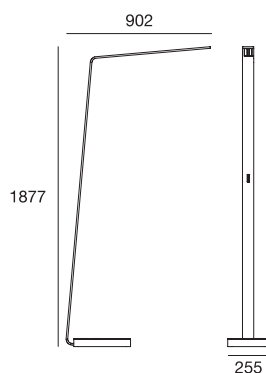

type

White	CRI 90	7116
Grey	CRI 90	7117

colour

3000 K 2760 lm

optics

diffused

Lama_Tab | Table Lamp | 220-240 V | topLED 9 W

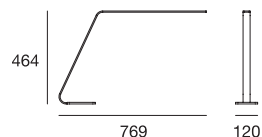

type

White	CRI 90	7112
Grey	CRI 90	7114

colour

3000 K 624 lm

optics

diffused

.Lama



.Seen from the side,
Lama reveals its minimalist essence:
the product disappears leaving
behind a neat bright line.







Lighting rings freely suspended.

Available in two diameters in the suspension and ceiling version, or as wall lamp. A suspension created to light large retail or living spaces. It has a white polyethylene body and dimming LED source. Larger version is ideal for showroom, hotel, commercial spaces and important public spaces. Smaller one, is perfect for small hotel reception or high level residence

.Saturn

design Linea Light Group, 2014







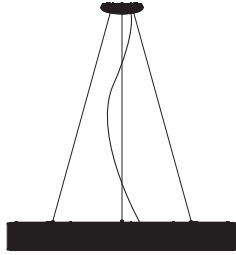

Technical Info

Saturn_P | Pendant luminaires | 220-240 V | topLED 33 W

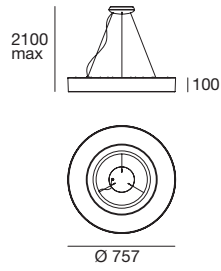

type

White CRI 90 **7652**

colour

3000 K 4016 lm

optics

diffused

Saturn_P | Pendant luminaires | 220-240 V | topLED 98 W

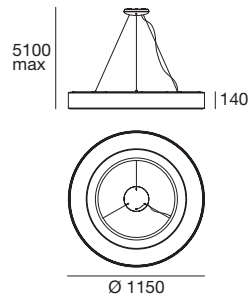

type

White CRI 90 **7650**

colour

3000 K 13261 lm

optics

diffused

Saturn_S | Ceiling luminaires | 220-240 V | TopLED 33 W



179 |  | 100

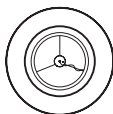

Ø 757

type

White CRI 90 **7653**

colour

3000 K 4016 lm

optics

diffused

Saturn_S | Ceiling luminaires | 220-240 V | TopLED 98W



213 |  | 140

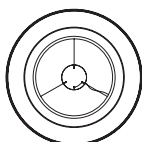

Ø 1150

type

White CRI 90 **7651**

colour

3000 K 13261 lm

optics

diffused

type

White CRI 90 **7654**

colour

3000 K 1480 lm

optics

diffused

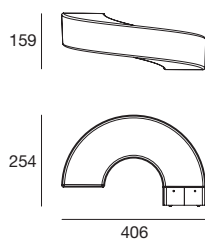

cod. 7654
Saturn_W
Wall light



.Saturn



.Has the ring around Saturn
ever looked boring?
Never in a billion years!







Reflections in white. Orbiting body two centimeters thick. Kyklos_P1 is a thin matte white polyurethane ring, with indirect main emission. Kyklos_P2 with a second upper ring, transforming the lamp in doubled emission. Available in three wattages and two dimensions, all versions are dimmable with DALI protocol. Wall mounted lamp with a grazing, suggestive light beams, ideal for contract and private residences

.Kyklos

design Linea Light Group, 2014



reddot award 2015
winner









Technical Info

Kyklos_P1 | Pendant luminaires | 220-240 V | topLED 42 W

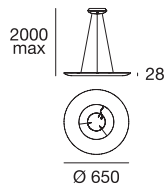

type

White CRI 90 **7980**

colour

3000 K 4173 lm

optics

diffused

Kyklos_P1 | Pendant luminaires | 220-240 V | topLED 55 W

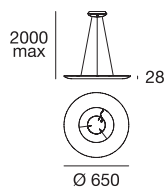

type

White CRI 90 **7981**

colour

3000 K 5564 lm

optics

diffused

Kyklos_P1 | Pendant luminaires | 220-240 V | topLED 91 W

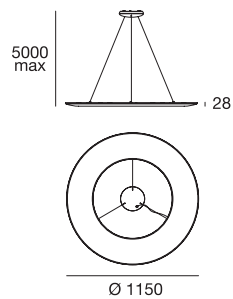

type

White CRI 90 **7982**

colour

3000 K 9160 lm

optics

diffused

Kyklos_P2 | Pendant luminaires | 220-240 V | topLED 58 W

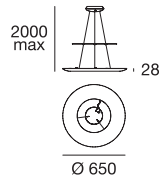

type

White CRI 90 **7983**

colour

3000 K 4173 lm

optics

diffused

Kyklos_P2 | Pendant luminaires | 220-240 V | topLED 77 W

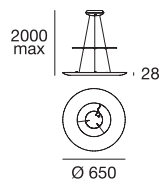

type

White CRI 90 **7984**

colour

3000 K 5564 lm

optics

diffused

Kyklos_P2 | Pendant luminaires | 220-240 V | topLED 116 W

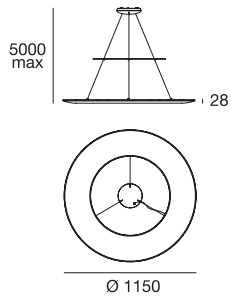

type

White CRI 90 **7985**

colour

3000 K 9180 lm

optics

diffused

Kyklos_W | Wall Light | 220-240 V | topLED 19 W

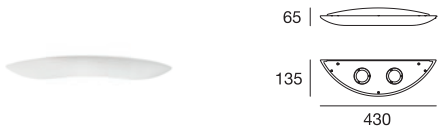
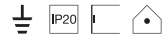

type

White CRI 90 **7740**

colour

3000 K 1500 lm

optics

diffused

accessories



KIT0026

Dimmer

Kyklos_W | Wall Light | 220-240 V | topLED 38 W

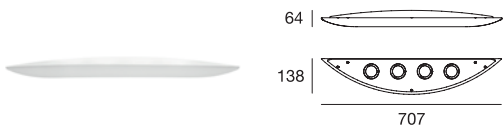
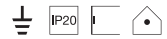

type

White CRI 90 **7741**

colour

3000 K 3000 lm

optics

diffused

accessories



KIT0026

Dimmer

cod. 7740
Kyklos_W
Wall light



.Kyklos



.Shade that defines the elegance of a room, designed to create charming indirect light effects.

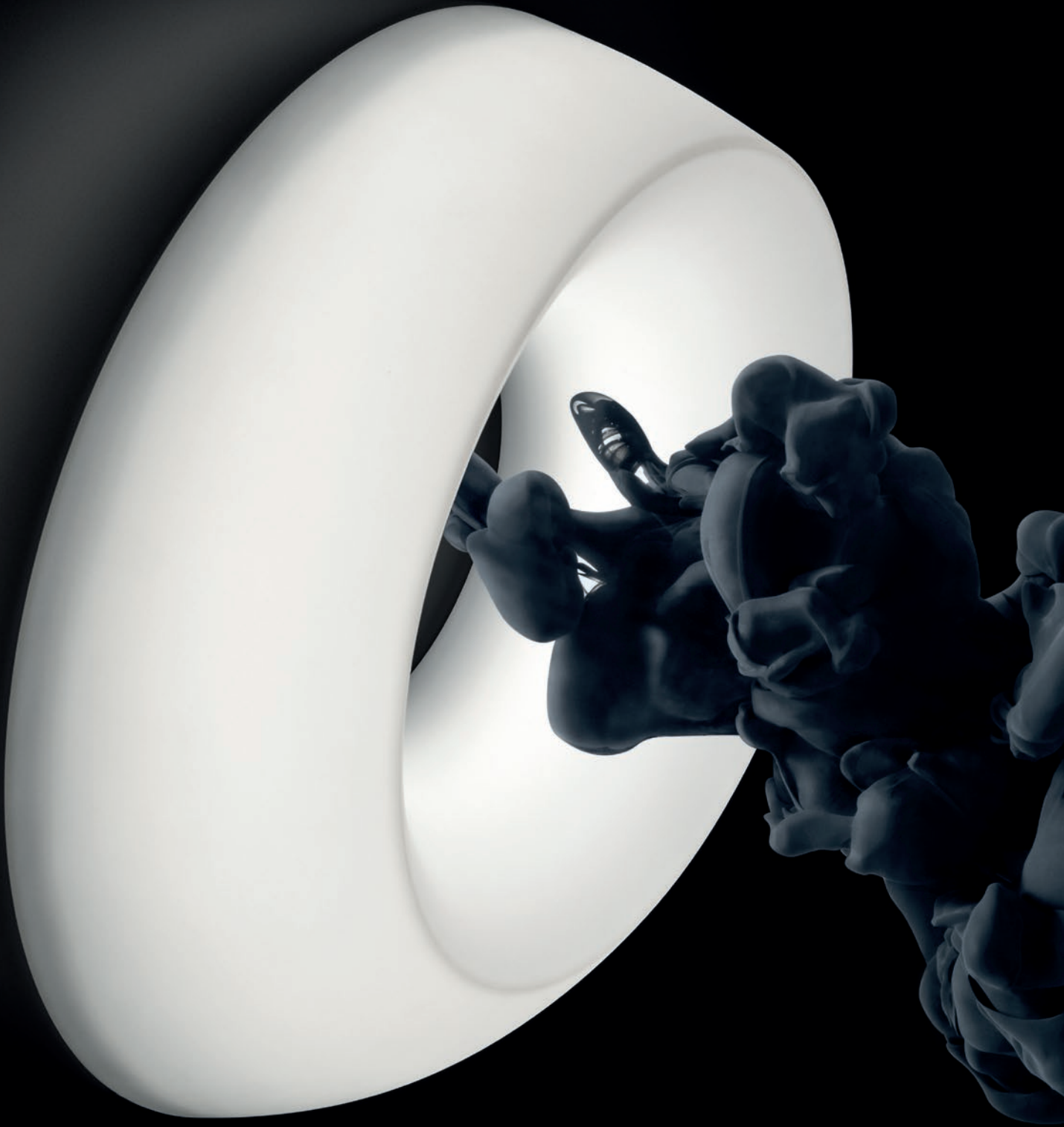





Asymmetric and subversive geometry.

Light and material, geometry and design, merged in a single rounded and asymmetric lamp. In white polystyrene, integrated with the aluminum base with a very performative magnetic clamp, LED driverless source. Available in two dimensions, perfect for modular visual high impact compositions. Suitable in ceiling and wall mounted options. Pio and Tito Toso has defined a dynamic and quite imperfect shaped object, contrasting with rigorous and minimal architecture

.Oblix

design Pio & Tito Toso, 2016

Oblix





Oblix





Technical Info

Oblix | Ceiling luminaires | 220-240 V | topLED 41 W

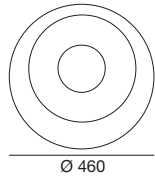

type

White CRI 90 **7960**

colour

3000 K 2980 lm

optics

diffused

accessories



KIT0026

Dimmer

Oblix | Ceiling luminaires | 220-240 V | topLED 64 W

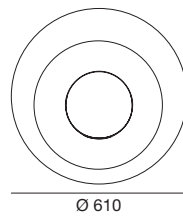

type

White CRI 90 **7961**

colour

3000 K 4938 lm

optics

diffused

accessories



KIT0026

Dimmer

.Oblix



.Asymmetric and irreverent,
its unconventional look only
adds to its charm.

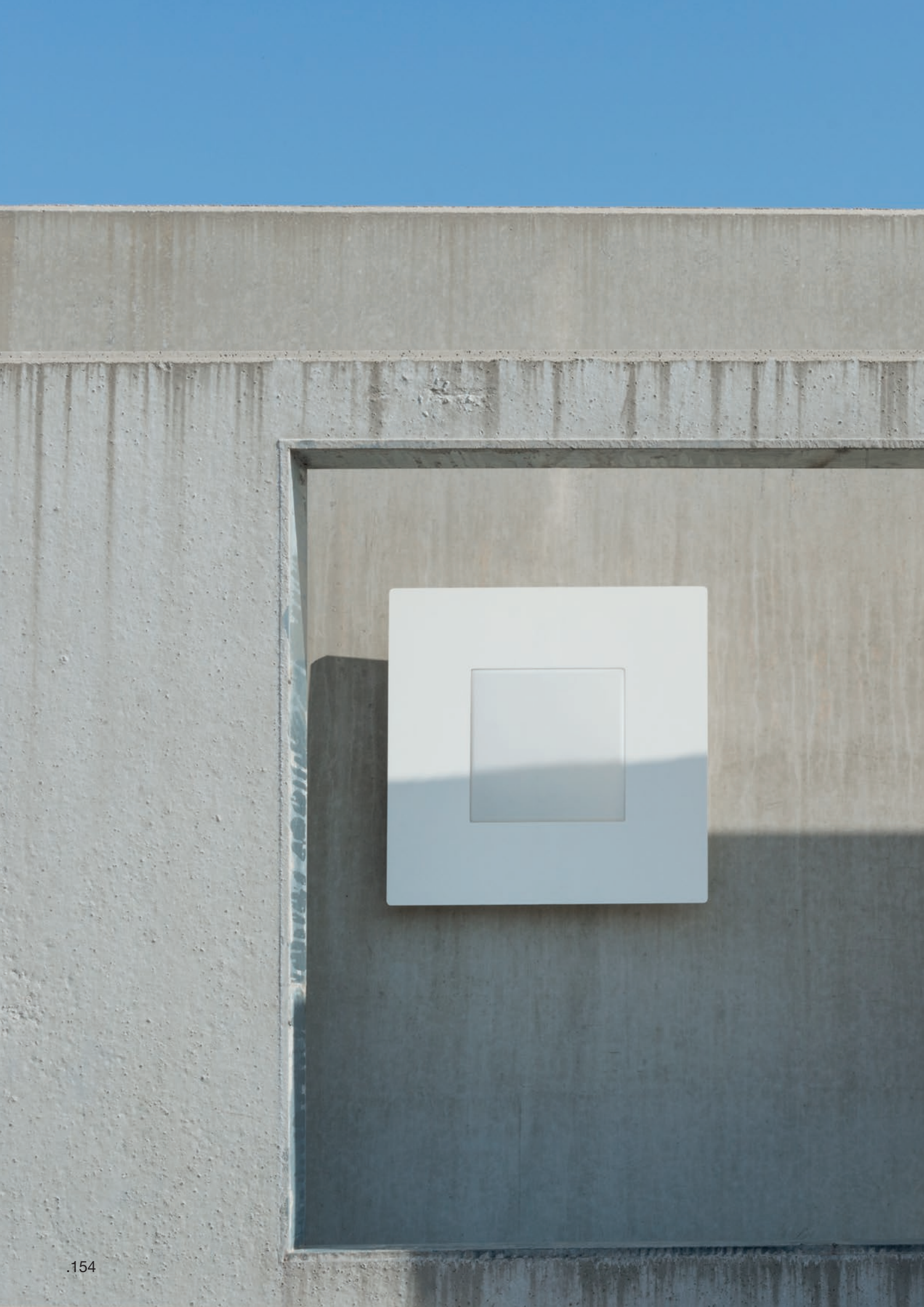



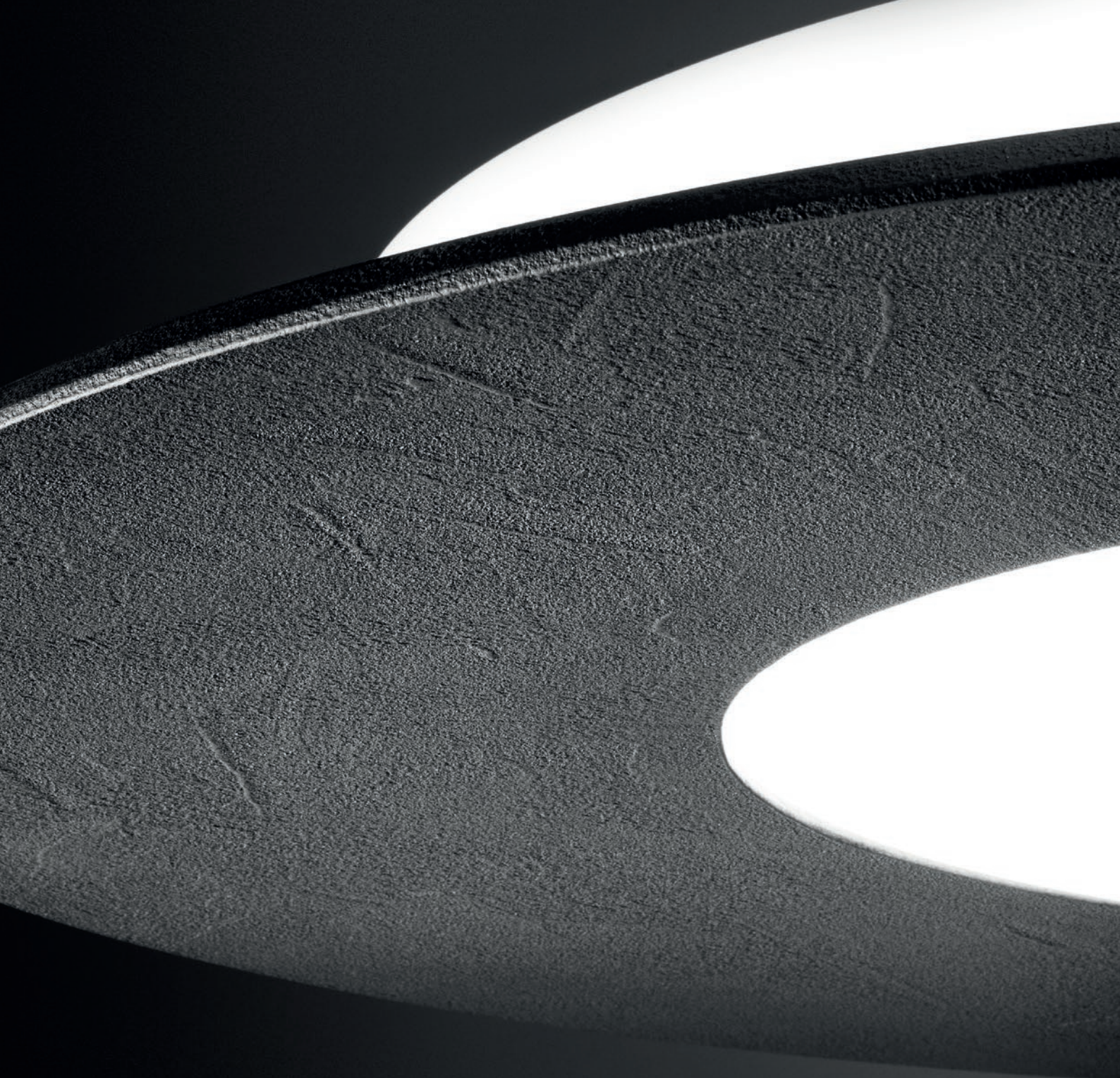

Tactile material over perfect shapes.

Available in two versions, suspension or wall mounted. A rigorous square ideal for hotel and residences, rectangular and the new circle version, organic and versatile. Polythene diffuser is placed in a wooden body painted white or concrete finish, a porous effect following the contemporary trends. Neat and clear shapes, reinvented in modern and minimal way, creates a multifaceted and multifunction family

.Square

design Linea Light Group, 2014













Technical Info

Square_PQ | Pendant luminaires | 220-240 V | topLED 28 W

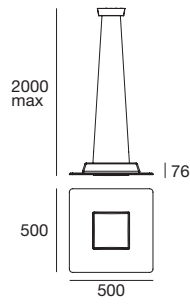

type

White	CRI 90	7996
St.Grey	CRI 90	7997

colour

3000 K 3062 lm

optics

diffused

Square_PQ | Pendant luminaires | 220-240 V | topLED 37 W

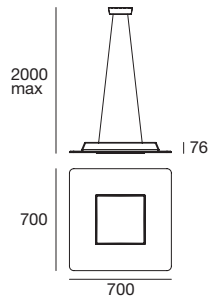

type

White	CRI 90	8000
St.Grey	CRI 90	8001

colour

3000 K 4101 lm

optics

diffused

Square_PQ | Pendant luminaires | 220-240 V | topLED 39 W

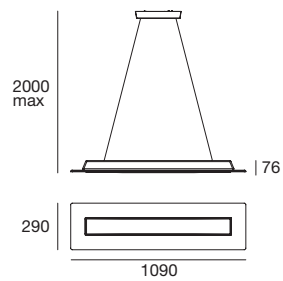

type

White	CRI 90	8003
St.Grey	CRI 90	8004

colour

3000 K 5127 lm

optics

diffused

Square_SQ | Ceiling luminaires | 220-240 V | topLED 28 W

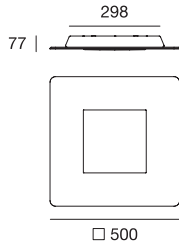

type

White	CRI 90	7682
St.Grey	CRI 90	7995

colour

3000 K 3062 lm

optics

diffused

Square_SQ | Ceiling luminaires | 220-240 V | topLED 37 W

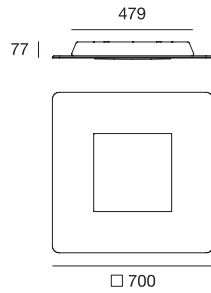

type

White	CRI 90	7998
St.Grey	CRI 90	7999

colour

3000 K 4101 lm

optics

diffused

Square_SQ | Ceiling luminaires | 220-240 V | topLED 39 W

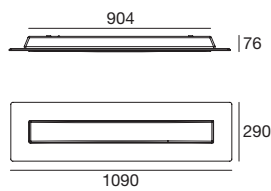

type

White	CRI 90	7690
St.Grey	CRI 90	8002

colour

3000 K 5127 lm

optics

diffused

Square_PR | Pendant luminaires | 220-240 V | topLED 23 W

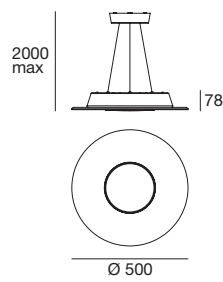

type

White	CRI 90	7989
St.Grey	CRI 90	7990

colour

3000 K 2702 lm

optics

diffused

Square_PR | Pendant luminaires | 220-240 V | topLED 32 W

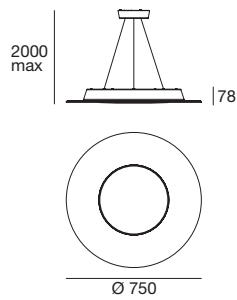

type

White	CRI 90	7993
St.Grey	CRI 90	7994

colour

3000 K 3935 lm

optics

diffused

Square_SR | Ceiling luminaires | 220-240 V | topLED 23 W

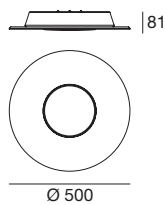

type

White	CRI 90	7987
St.Grey	CRI 90	7988

colour

3000 K 2702 lm

optics

diffused

Square_SR | Ceiling luminaires | 220-240 V | topLED 32 W

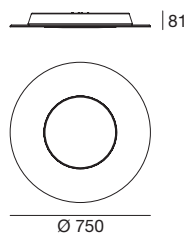

type

White	CRI 90	7991
St.Grey	CRI 90	7992

colour

3000 K 3935 lm

optics

diffused

.Square



.Squaring the circle:
primary geometric shapes
meet refined materials,
light envelopes new forms.



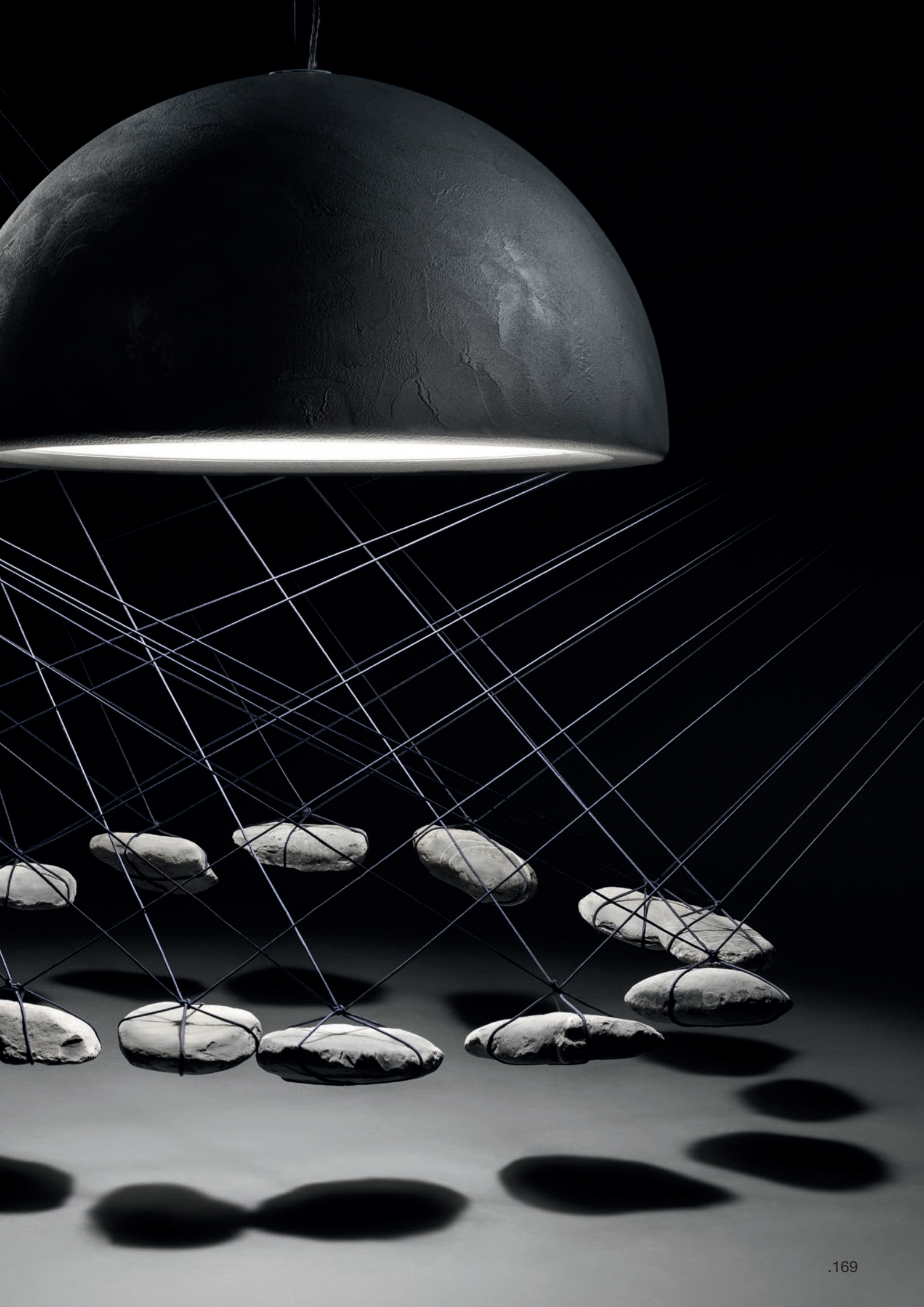



Luminous and concrete material.

A dome, revisited archetypic shape in contemporary twist. Covered with new finishes, adding to opal polystyrene the concrete, corten and chalk daring finishes. The opal white diffuser brings out the light, the LED source integrated with Warm Tune™ technology (except for opal version) allows dimmable luminous intensity and color temperature control simultaneously. Available in two diameters, suitable for every private residence style or contract solution

.Entourage

design Linea Light Group, 2009

redesign Linea Light Group, 2016







Warm Tune™_Technology

Change the light, change the mood!

Traditional light



@ 100%



Relaxing light

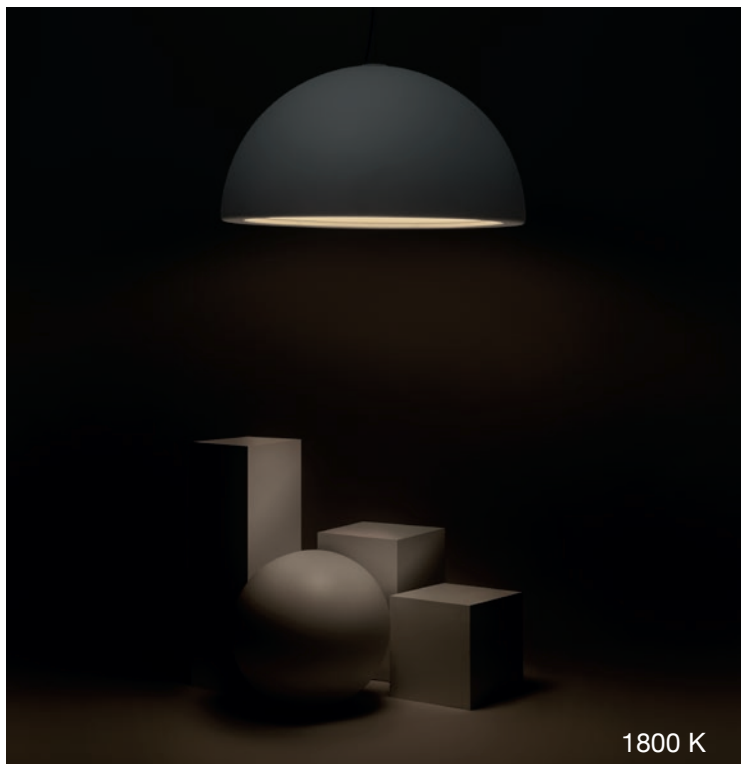

@ 5%



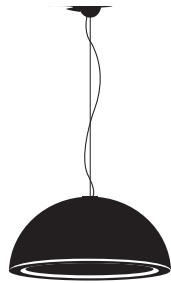

Technical Info

Entourage_P1 | Pendant luminaires | 220-240 V | arrayLED 16 W

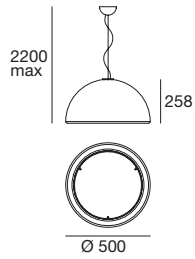

type

St.Grey	CRI 90	7676
Wh.Gyp.	CRI 90	7677
Cor-ten	CRI 90	7678

colour

Warm Tune 845 lm

optics

diffused

accessories



KIT0026

Dimmer

Entourage_P1 | Pendant luminaires | 220-240 V | arrayLED 28 W

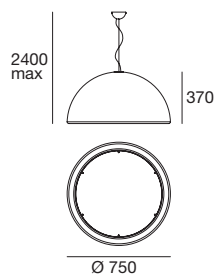

type

St.Grey	CRI 90	7694
Wh.Gyp.	CRI 90	7695
Cor-ten	CRI 90	7696

colour

Warm Tune 1790 lm

optics

diffused

accessories



KIT0026

Dimmer

Entourage_P1 | Pendant luminaires | 220-240 V | arrayLED 56 W

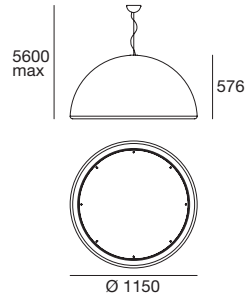

type

St.Grey	CRI 90	7697
Wh.Gyp.	CRI 90	7698
Cor-ten	CRI 90	7699

colour

Warm Tune 3580 lm

optics

diffused

accessories



KIT0026

Dimmer

Entourage_P1 | Pendant luminaires | 220-240 V | 2xE27

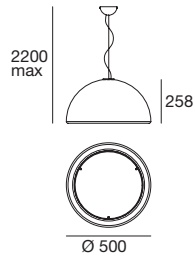

type

St.Grey	7663
Wh.Gyp.	7664
Cor-ten	7665

source

2x46 W Max

optics

diffused

Entourage_P1 | Pendant luminaires | 220-240 V | 3xE27

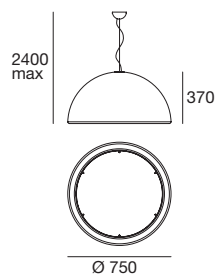

type

St.Grey	7666
Wh.Gyp.	7667
Cor-ten	7668

source

3x46 W Max

optics

diffused

Entourage_P1 | Pendant luminaires | 220-240 V | 5xE27

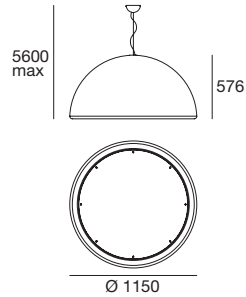

type

St.Grey	7669
Wh.Gyp.	7670
Cor-ten	7671

source

5x46 W Max

optics

diffused

Entourage_P2 | Pendant luminaires | 220-240 V | 2xE27

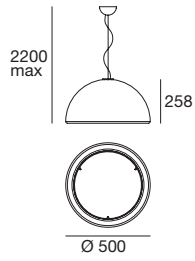

type

White **7660**

source

2x46 W max

optics

diffused

Entourage_P2 | Pendant luminaires | 3xE27

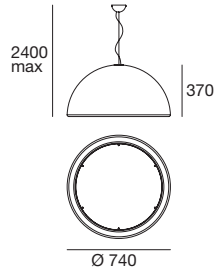

type

White **7661**

source

3x46 W max

optics

diffused

Entourage_P2 | Pendant luminaires | 5xE27

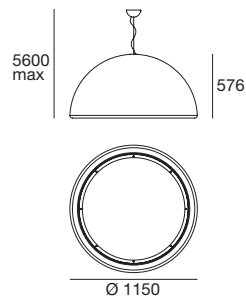

type

White **7662**

source

5x46 W max

optics

diffused

.Entourage



.The classic semi-circle combined with new materials, a vintage look that embraces modern finishes.







Refined, invisible and transparent.

Evolution of the iconic O-Line, completely esthetically and technologically revised and upgraded. The new suspended unit is a transparent serigraphy plate, adopting OptiLight Technology™. The spreading serigraphy is esthetically elegant when light on, becoming completely transparent when light off. Light spreads clear and smooth from the LED source, integrated in the thin aluminum structure. Available in white or in polished aluminum, perfect for contemporary living

.Opti-Line

design Linea Light Group, 2009

redesign Linea Light Group, 2016







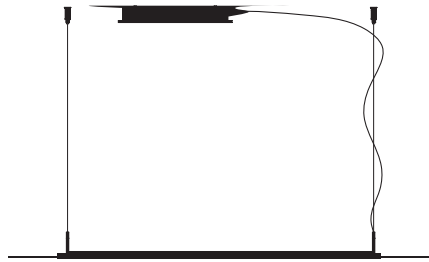

Technical Info

Opti-Line_P | Pendant luminaires | 220-240 V | topLED 47 W

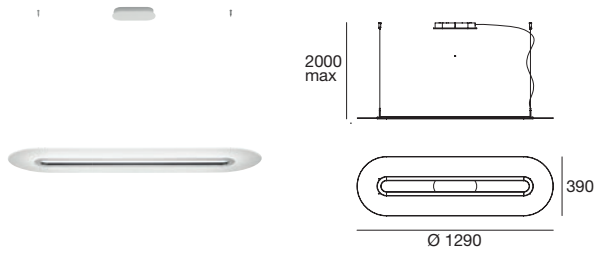

type

White	CRI 90	8035
Polish Al.	CRI 90	8036

colour

3000 K 5685 lm

optics

diffused

Opti-Line_P | Pendant luminaires | 220-240 V | topLED 47 W

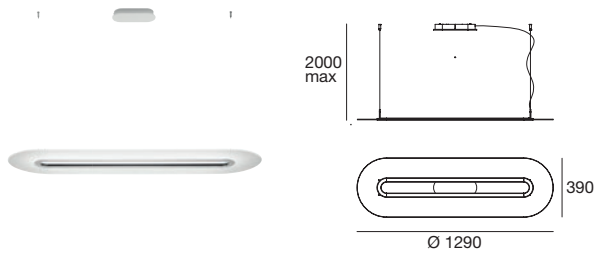

type

White	CRI 90	8037
Polish Al.	CRI 90	8038

colour

3000 K 5685 lm

optics

diffused

cod. 8037
Opti-Line_P
Pendant luminaires



.Opti-Line



.A tribute to the classic
car racing track,
a celebration of speed and
of the oval shape.







Ironic light. The cloud's lightness take shape in the sinuous lines of this ironic light sculpture. Mr. Magoo, inspired by the homonymous character's hat, it's a hilarious and versatile lamp. Available in three versions: suspension, ceiling or curved floor and in different sizes, suitable for every kind of living space. The polythene unit holds a LED or fluorescent source. Ideal for residence or contract space, contemporary or classic

.Mr.Magoo

design Linea Light Group, 2010



reddot award 2015
winner











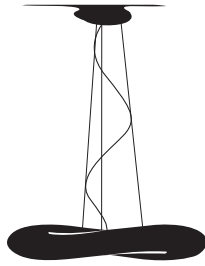

Technical Info

Mr.Magoo_P | Pendant luminaires | 220-240 V | topLED 23 W

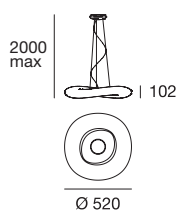

type

White CRI 90 8005

colour

3000 K 2655 lm

optics

diffused

Mr.Magoo_P | Pendant luminaires | 220-240 V | topLED 32 W

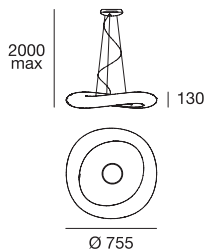

type

White CRI 90 8007

colour

3000 K 3730 lm

optics

diffused

Mr.Magoo_P | Pendant luminaires | 220-240 V | topLED 96 W

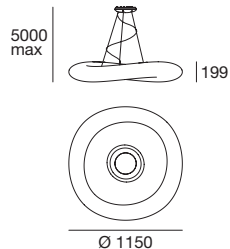

type

White CRI 90 7788

colour

3000 K 12400 lm

optics

diffused

Mr.Magoo_P | Pendant luminaires | 220-240 V | 1x2GX13

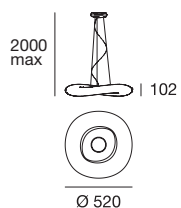

type

White 7790

source

Fluorescent 1x22 W (included)

optics

diffused

Mr.Magoo_P | Pendant luminaires | 220-240 V | 1x2GX13

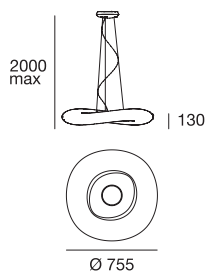

type

White 6860

source

Fluorescent 1x55 W (included)

optics

diffused

Mr.Magoo_P | Pendant luminaires | 220-240 V | 4x2G11

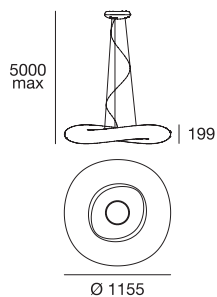

type

White 6858

source

Fluorescent 4x36 W (included)

optics

diffused

Mr.Magoo_S | Ceiling luminaires | 220-240 V | topLED 23 W



120

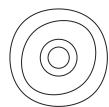

Ø 520

type

White CRI 90 8006

colour

3000 K 2655 lm

optics

diffused

Mr.Magoo_S | Ceiling luminaires | 220-240 V | topLED 32 W



140

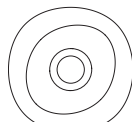

Ø 760

type

White CRI 90 8008

colour

3000 K 3730 lm

optics

diffused

Mr.Magoo_S | Ceiling luminaires | 220-240 V | topLED 96 W



215

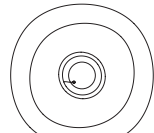

Ø 1150

type

White CRI 90 7789

colour

3000 K 12400 lm

optics

diffused

Mr.Magoo_S | Ceiling luminaires | 220-240 V | 1x2GX13

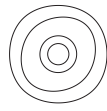

Ø 520

type

White 7792

source

Fluorescent 1x22 W (included)

optics

diffused

Mr.Magoo_S | Ceiling luminaires | 220-240 V | 1x2GX13

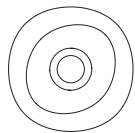

Ø 760

type

White 6857

source

Fluorescent 1x55 W (included)

optics

diffused

Mr.Magoo_S | Ceiling luminaires | 220-240 V | 4x2G11

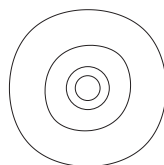

Ø 1155

type

White 7799

source

Fluorescent 4x36 W (included)

optics

diffused

Mr.Magoo_FL | Free standing | 220-240 V | topLED 23 W



type

White CRI 90 **8009**

colour

3000 K 2655 lm

optics

diffused

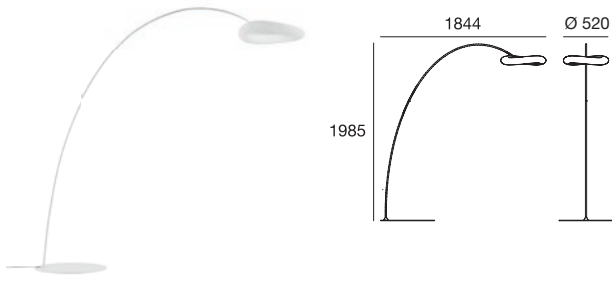

cod. 8009
Mr.Magoo_FL
Free standing



.Mr.Magoo



.Named after the unforgettable character born of John Hubley's genius, it reproduces the curved brim of Mr. Magoo's famous hat.

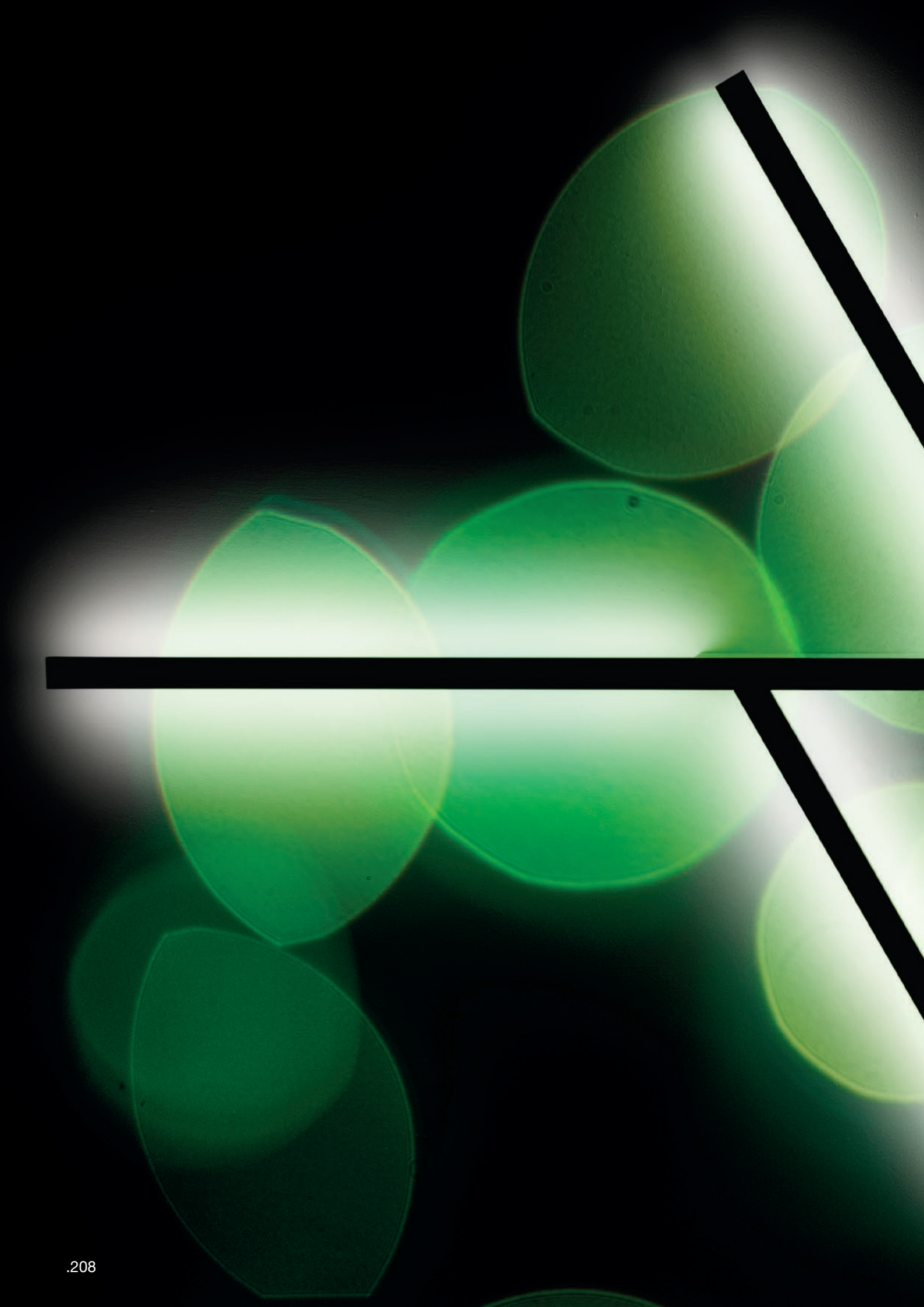

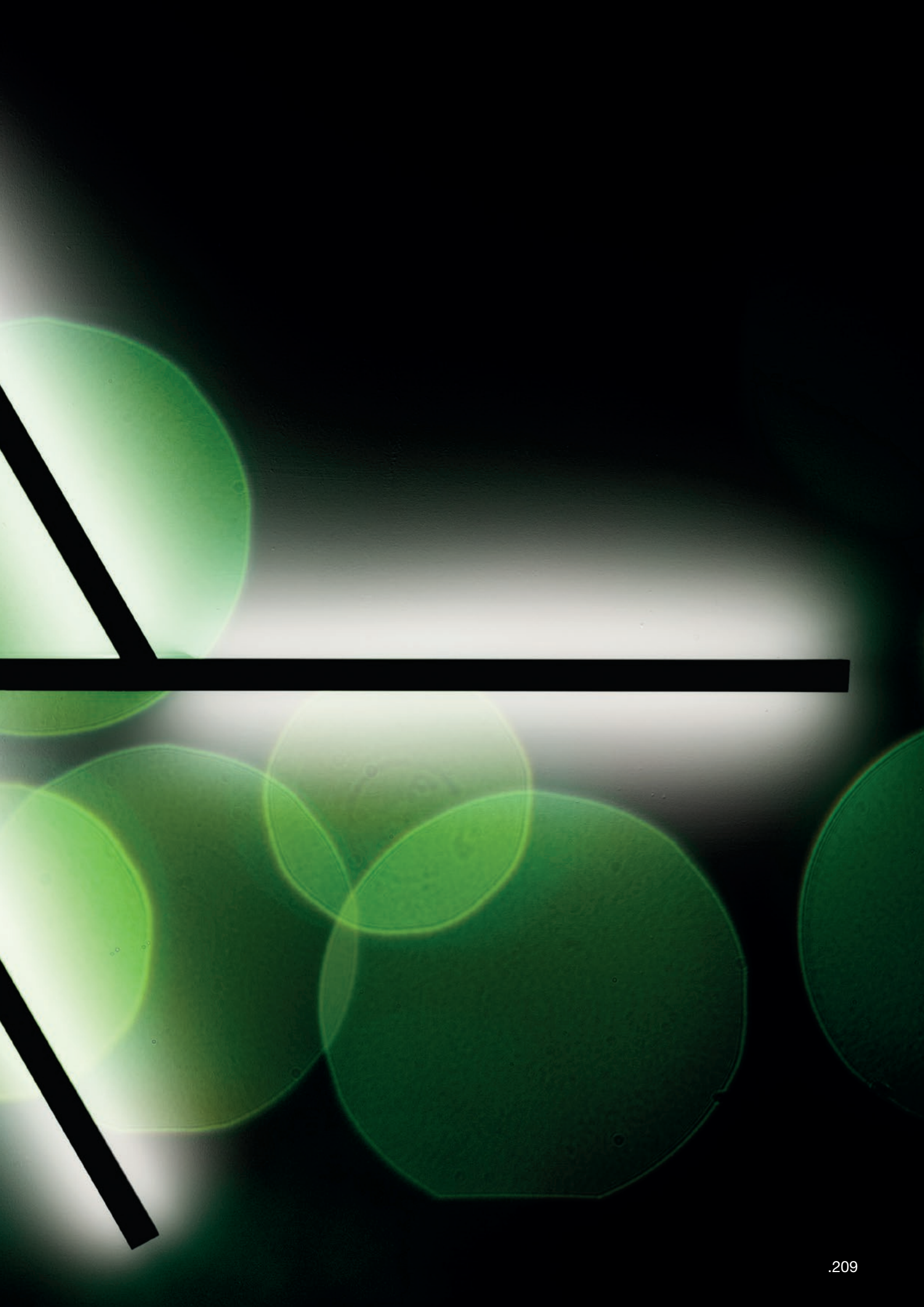



Geometric and technology perfection.

Perfect geometry and high technology meets in an esthetically daring lamp. Suitable to light hotel, resort or residence. Aluminum body in white or polished aluminum finish, PMMA diffuser with WallWasher optics that “wash” the walls with an indirect smooth and diffusive lighting. Available in four versions: ceiling, wall, floor or suspension. Peculiar solutions for the floor version, with concrete base enhancing minimalism and material; and for the suspension, with an adjustable hanging hook, suitable for sloped ceiling, as attics or trussed

.Xilema

design Linea Light Group, 2014



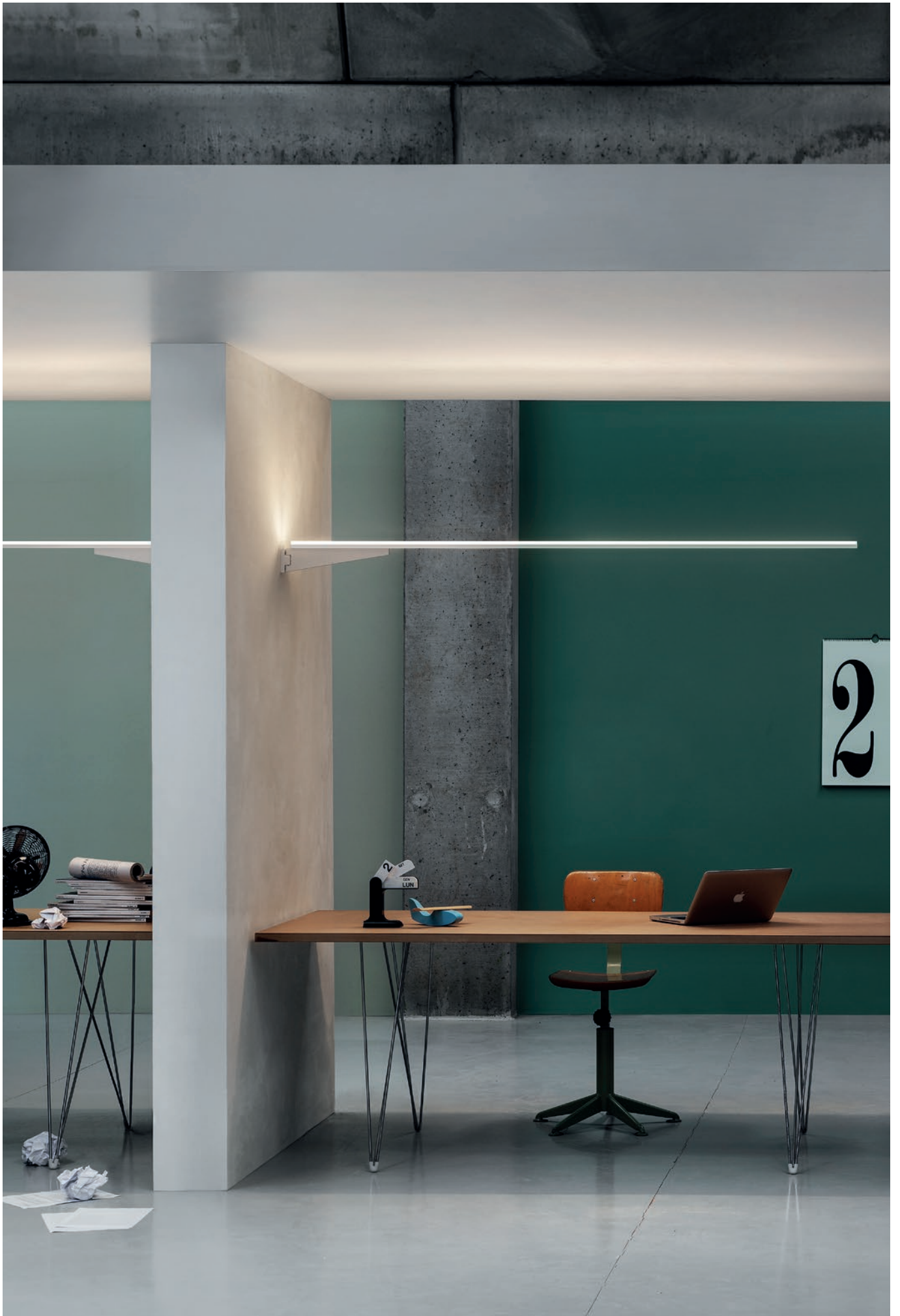













Technical Info

Xilema_P | Pendant luminaires | 220-240 V | topLED 25 W

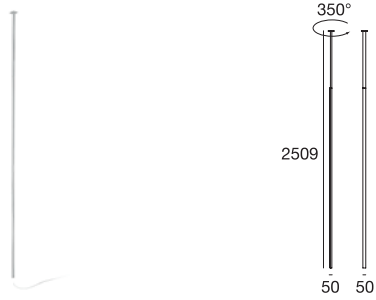

type

White	CRI 90	7773
Anod. Al.	CRI 90	7774

colour

3000 K 2914 lm

optics

Asym.

Xilema_S | Ceiling luminaires | 220-240 V | topLED 47 W

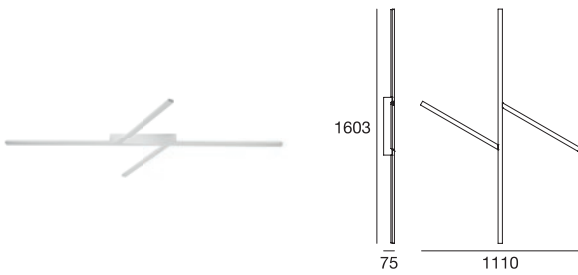

type

White	CRI 90	7769
Anod. Al.	CRI 90	7770

colour

3000 K 5736 lm

optics

Asym.

cod. 7773
Xilema_P
Pendant Luminaries



Xilema_W1 | Wall light | 220-240 V | topLED 17 W

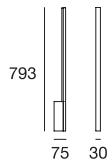

type

White CRI 90 **7765**

Anod. Al. CRI 90 **7766**

colour

3000 K 1996 lm

optics

Asym.

Xilema_W1 | Wall light | 220-240 V | topLED 25 W

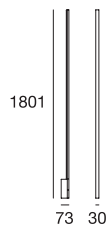

type

White CRI 90 **7777**

Anod. Al. CRI 90 **7778**

colour

3000 K 2914 lm

optics

Asym.

Xilema_WJ | Wall light | 220-240 V | topLED 25 W

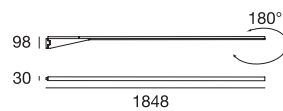

type

White CRI 90 **7775**

Anod. Al. CRI 90 **7776**

colour

3000 K 2914 lm

optics

Asym.

Xilema_W2 | Wall light | 220-240 V | topLED 34 W

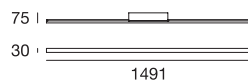

type

White CRI 90 **7767**

Anod. Al. CRI 90 **7768**

colour

3000 K 3992 lm

optics

Asym.

type

White	CRI 90	7771
Anod. Al.	CRI 90	7772

colour

3000 K 2915 lm

optics

Asym.

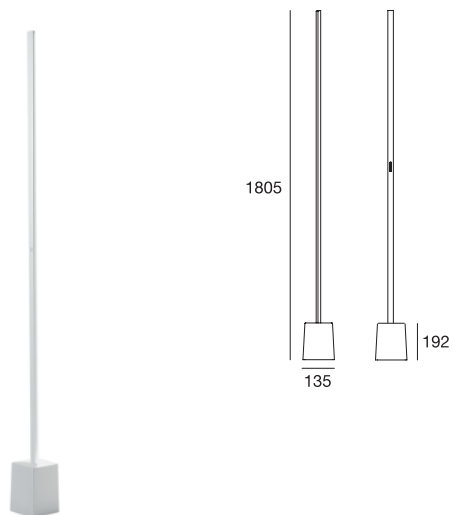

cod. 7771
Xilema_FL
Free Standing



.Xilema



.Inspired by the veins
of leaves after which
it is named.





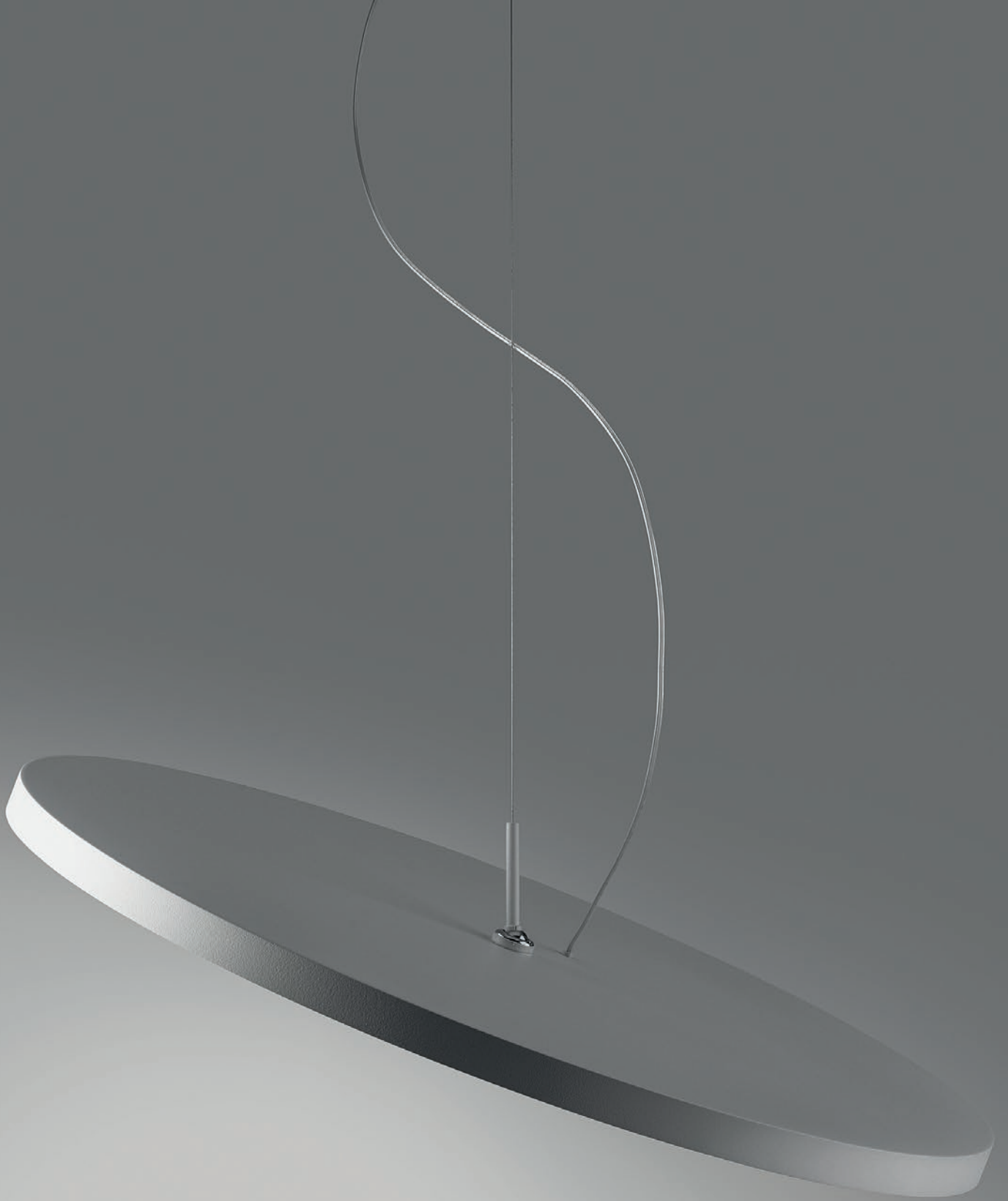

Motion's light thousand games.

The ring, designed by Oriano Favaretto, moves in space, sinuous and precise. The suspended tilting structure makes the lamp dynamic and functional. Through the PMMA silkscreened diffuser, the aluminum ring holding the LED source spreads a smooth and wrapping light. Light Game is also provided in ceiling version, in two options: big, providing a rotation and vertical axis tilting; small, able to move from the center, providing a complete rotation

.Light Game

design Oriano Favaretto, 2014





Light Game_S

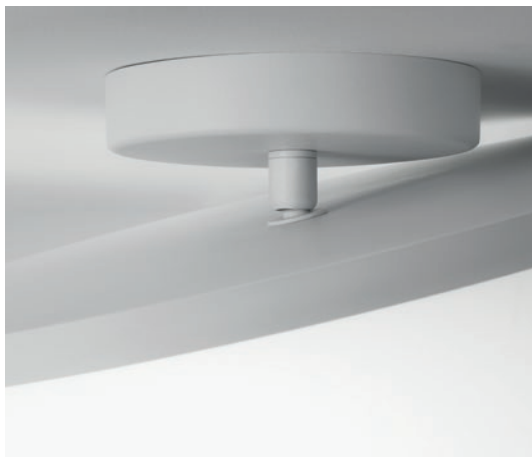

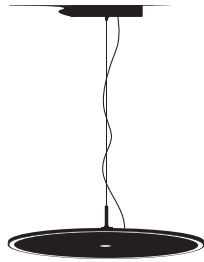

Technical Info

Light Game_P | Pendant luminaires | 220-240 V | topLED 12 W

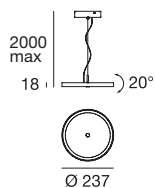

type

White CRI 90 **7746**

colour

3000 K 1449 lm

optics

diffused

Light Game_P | Pendant luminaires | 220-240 V | topLED 34 W

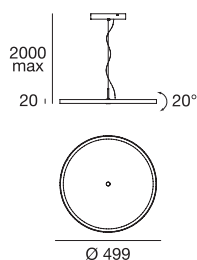

type

White CRI 90 **7748**

colour

3000 K 4065 lm

optics

diffused

Light Game_S | Ceiling luminaires | 220-240 V | topLED 12 W

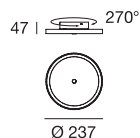

type

White CRI 90 **7745**

colour

3000 K 1449 lm

optics

diffused

Light Game_S | Ceiling luminaires | 220-240 V | topLED 34 W

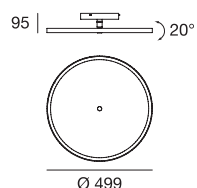

type

White CRI 90 **7747**

colour

3000 K 4065 lm

optics

diffused

.Light Game



.A light illuminating familiar
environment,
a bright disk that follows
my notes.

cit. Oriano Favaretto



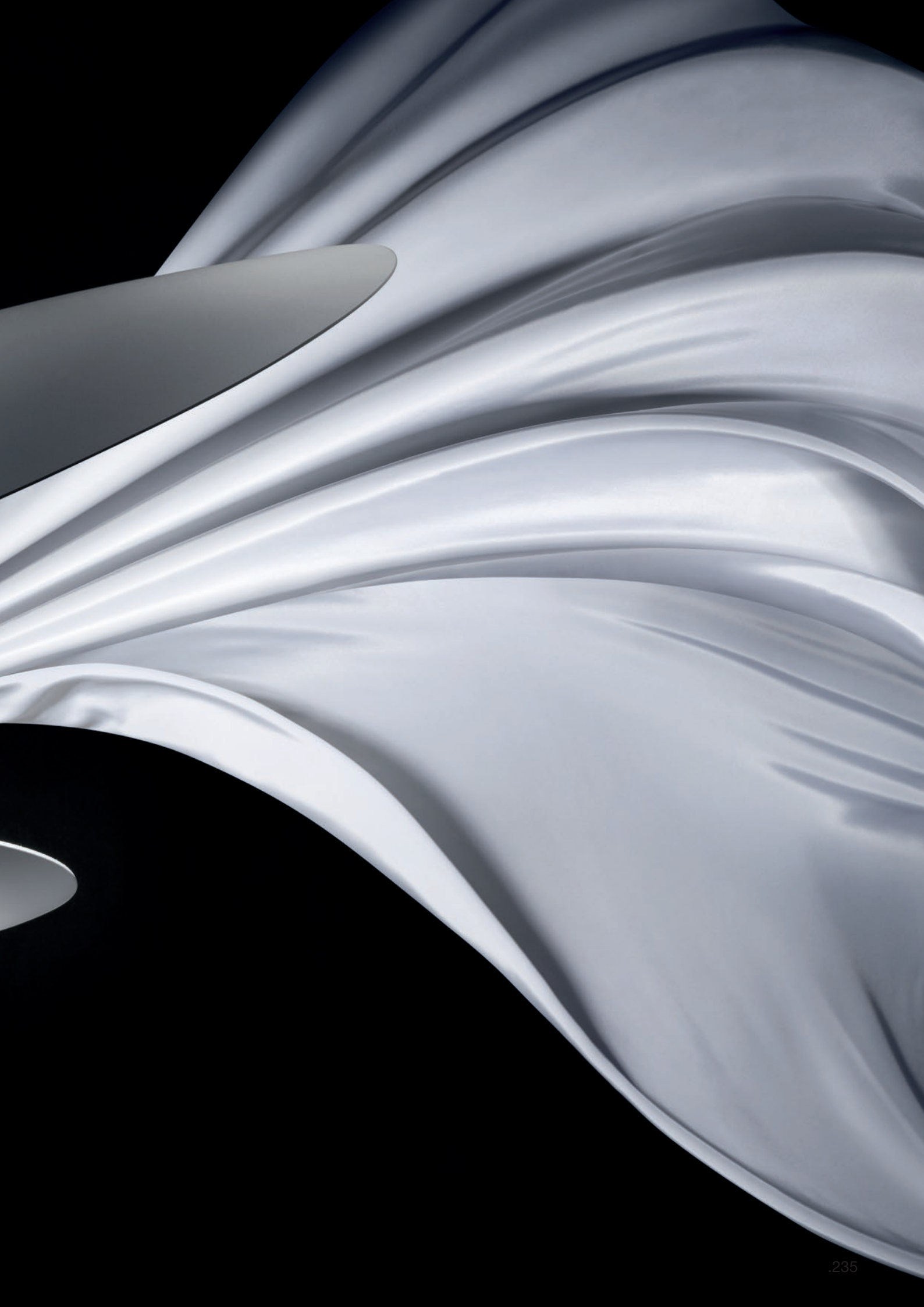



Reflection and movement, lighting and playing. Two parallel flying lighting rings. The lower directs light beam toward the upper adjustable aluminum diffuser, defined by a wrapped concavity, an interaction between indirect and homogeneous lighting. A suspension ideal to light contemporary and classical living spaces. High mobility, enriched by rings tilting, makes the floor version an eclectic reading wall lamp, defining an original hybrid version. The source vertical sliding on central cable, tensioned by a floor weight

.Madame Blanche

design Linea Light Group, 2016









Technical Info

Madame Blanche_P1 | Pendant luminaires | 220-240 V | topLED 32 W

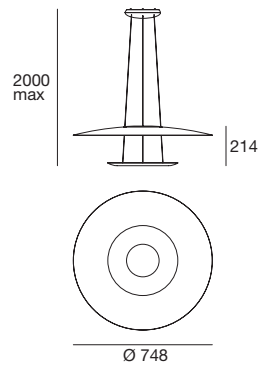

type

White CRI 90 **8175**

colour

3000 K 3730 lm

optics

diffused

Madame Blanche_P2 | Pendant luminaires | 220-240 V | 32 W

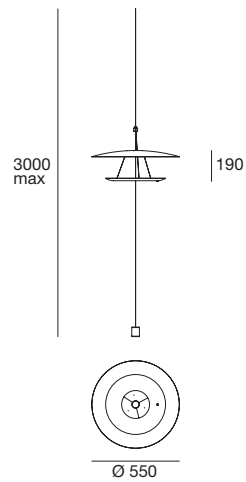

type

White CRI 90 **8178**

colour

3000 K 3730 lm

optics

diffused

cod. 8178
Madame Blanche_P2
Pendant luminaires



.Madame Blanche

.Reminiscent of the fluffy hats
so dear to the French ladies
of the fourteenth century,
it dresses candid white light
with refined elegance.







Elegance synthesis. A perfect contemporary elegance synthesis, modelling a minimal design lamp. Branch is a space shift, a straight vanishing line thanks to its double emission, made of aluminum with white and polished aluminum finishes. Homogeneous and precise direct downward light, wrapping the indirect one. Inside the case a LED source, hidden by a slightly back diffuser. Ideal for hotel or resort, offices or private residences

.Branch

design Linea Light Group, 2012



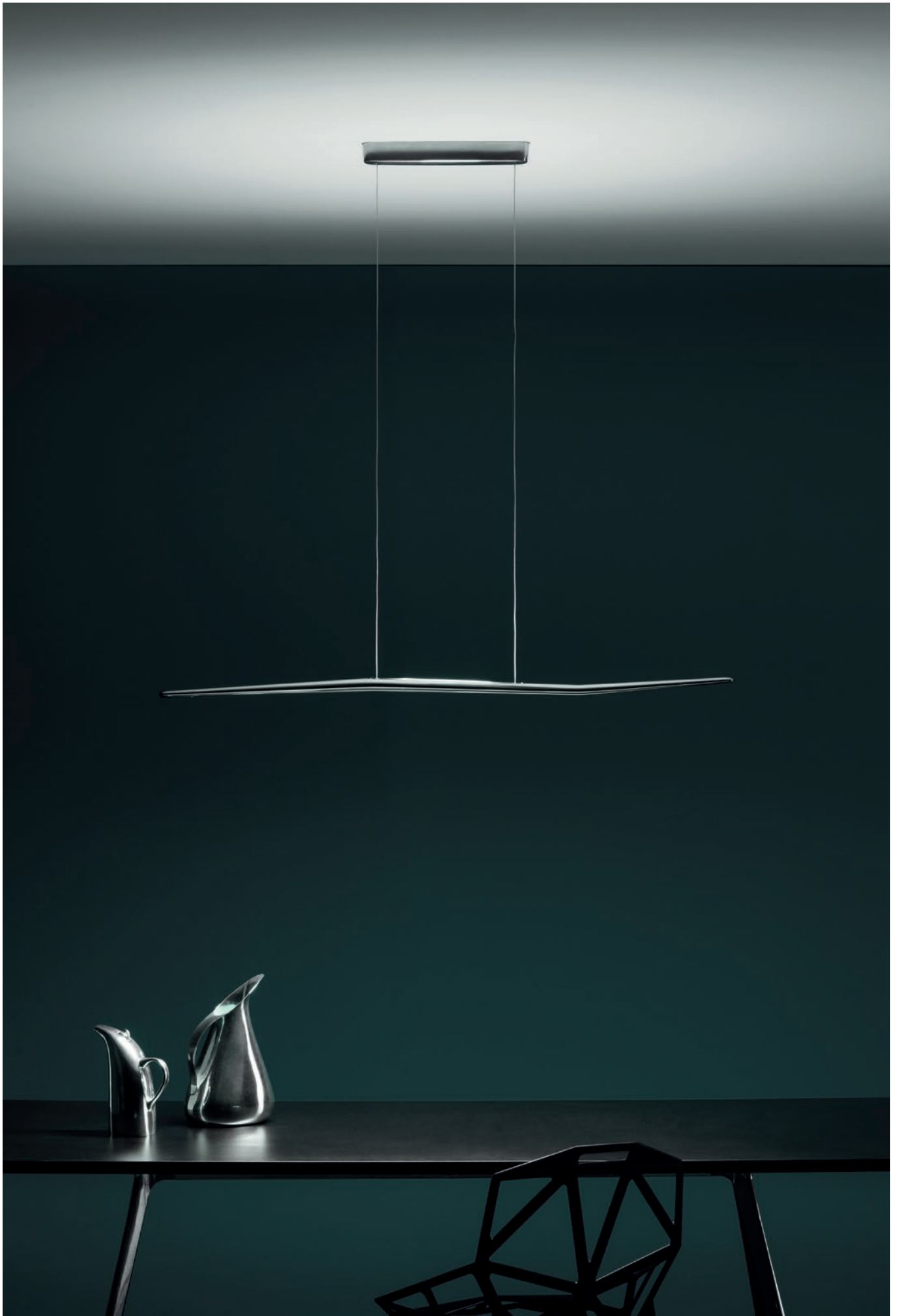





Technical Info

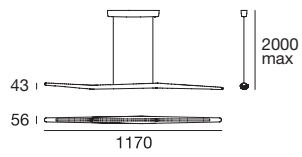

type

White	CRI 85	7465
Polish Al.	CRI 85	7466

colour

3000 K 2760 lm

optics

diffused

cod. 7465
Branch_P
Pendant luminaires



.Branch



.An elegant shape borrowed
from nature,
a fine branch
of minimalist simplicity.







Antique shape and materials for contemporary living. A suspension lamp available in two sizes. The smaller one allows cluster compositions. Available in two elegant and refined finish: polished white polyethylene or granular polycarbonate. Ideal to light open space, the smaller ones are suitable to complete, with geometric lighting cascades, reception, SPA or resort. The bigger one fill the space, with its smooth and seducing light

.Monarque

design Linea Light Group, 2016







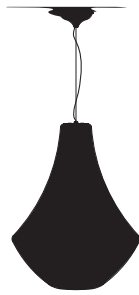

Technical Info

Monarque_P | Pendant luminaires | 220-240 V | 12 W

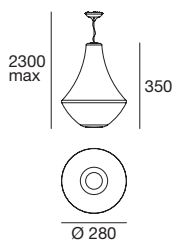

type

White	CRI 90	8022
Granular	CRI 90	8023

colour

3000 K 1434 lm

optics

diffused

Monarque_P | Pendant luminaires | 220-240 V | 38 W

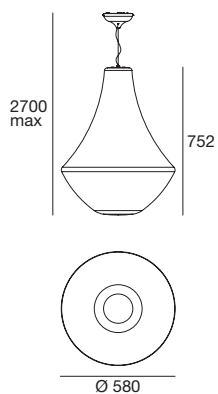

type

White	CRI 90	8024
Granular	CRI 90	8025

colour

3000 K 4701 lm

optics

diffused

cod. 8023_8025
Monarque_P
Pendant luminaires



.Monarque



.A vintage design combined with modern materials and shapes, a tribute to the classic crystal chandeliers of noble palaces.



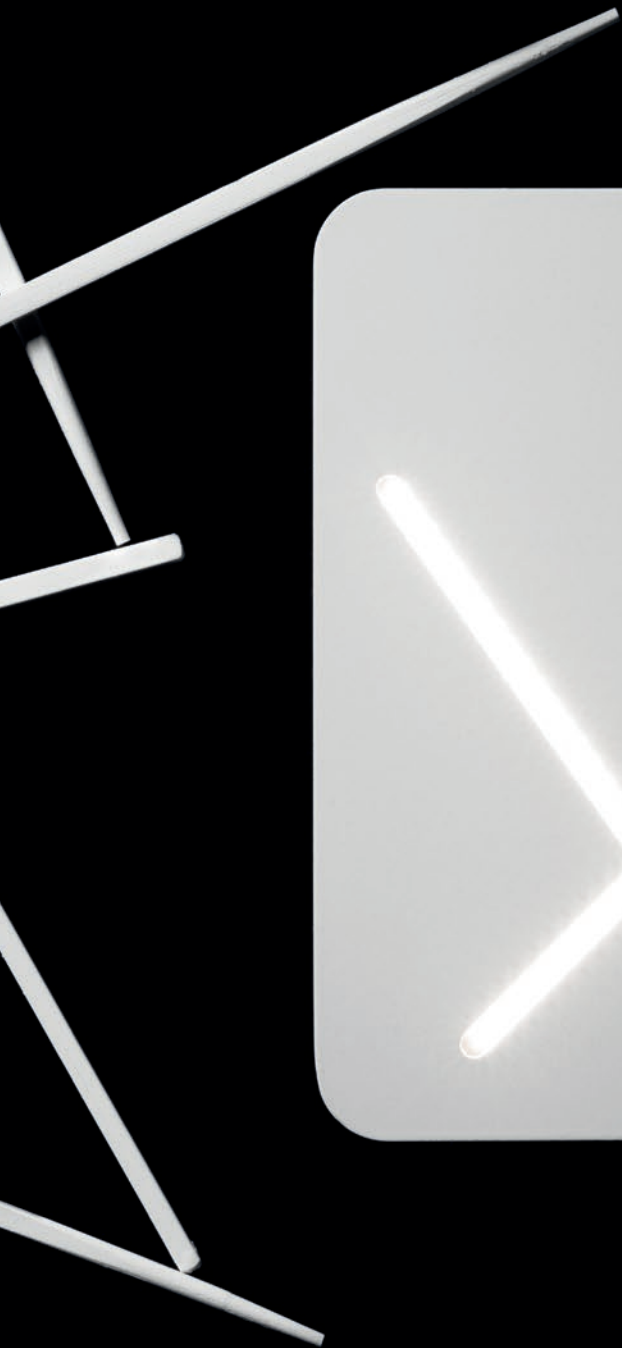



Functional rigorous and decorative minimalism. Square rounded surface, engraved by rigorous and precise lighting slits. Different versions, all defined by lighting crossed lines, allows to light and decorate every living space with a measured elegance. In thermoplastic material with satin polycarbonate diffuser, it is suitable in several options and sizes, answering to all functional and decorative needs. Ideal for offices, open and public spaces

.Next

design Linea Light Group, 2012





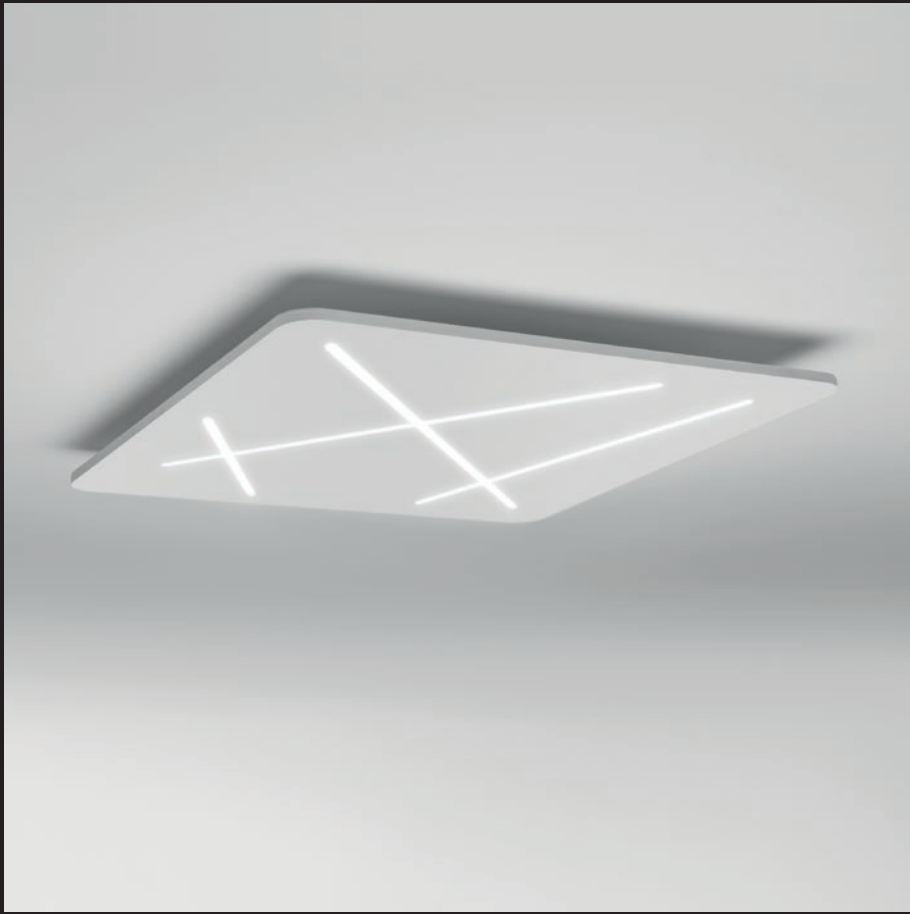



Technical Info

Next_S | Ceiling luminaires | 220-240 V | topLED 14 W

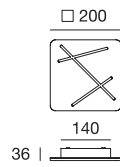

type

White CRI 85 **7440**

colour

3000 K 1035 lm

optics

diffused

Next_S | Ceiling luminaires | 220-240 V | topLED 46 W

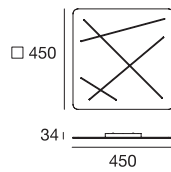

type

White CRI 85 **7441**

colour

3000 K 3312 lm

optics

diffused

Next_S | Ceiling luminaires | 220-240 V | topLED 73 W

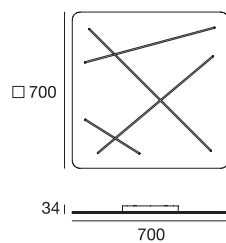

type

White CRI 85 **7442**

colour

3000 K 5244 lm

optics

diffused

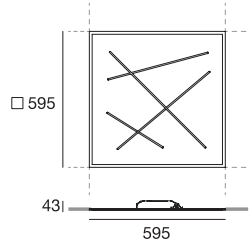
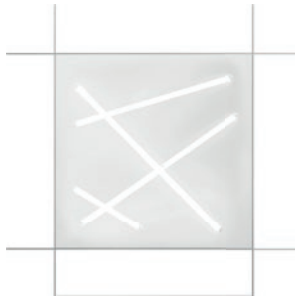

type

White CRI 85 **7445**

colour

3000 K 4140 lm

optics

diffused

cod. 7445
Next_C
Recessed Lights



Next_P | Pendant luminaires | 220-240 V | topLED 38 W

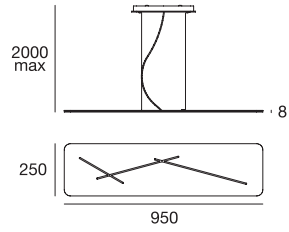

type

White CRI 85 **7444**

colour

3000 K 2760 lm

optics

diffused

Next_W | Ceiling luminaires | 220-240 V | topLED 21 W

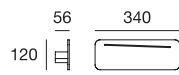
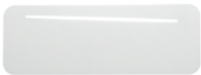

type

White CRI 90 **7447**

colour

3000 K 2505 lm

optics

diffused

cod. 7444

Next_P

Pendant luminaires



.Next



.Born of an ambitious plan:
bringing the charm of the large
architectural linear ceiling
light in a single luminaire.



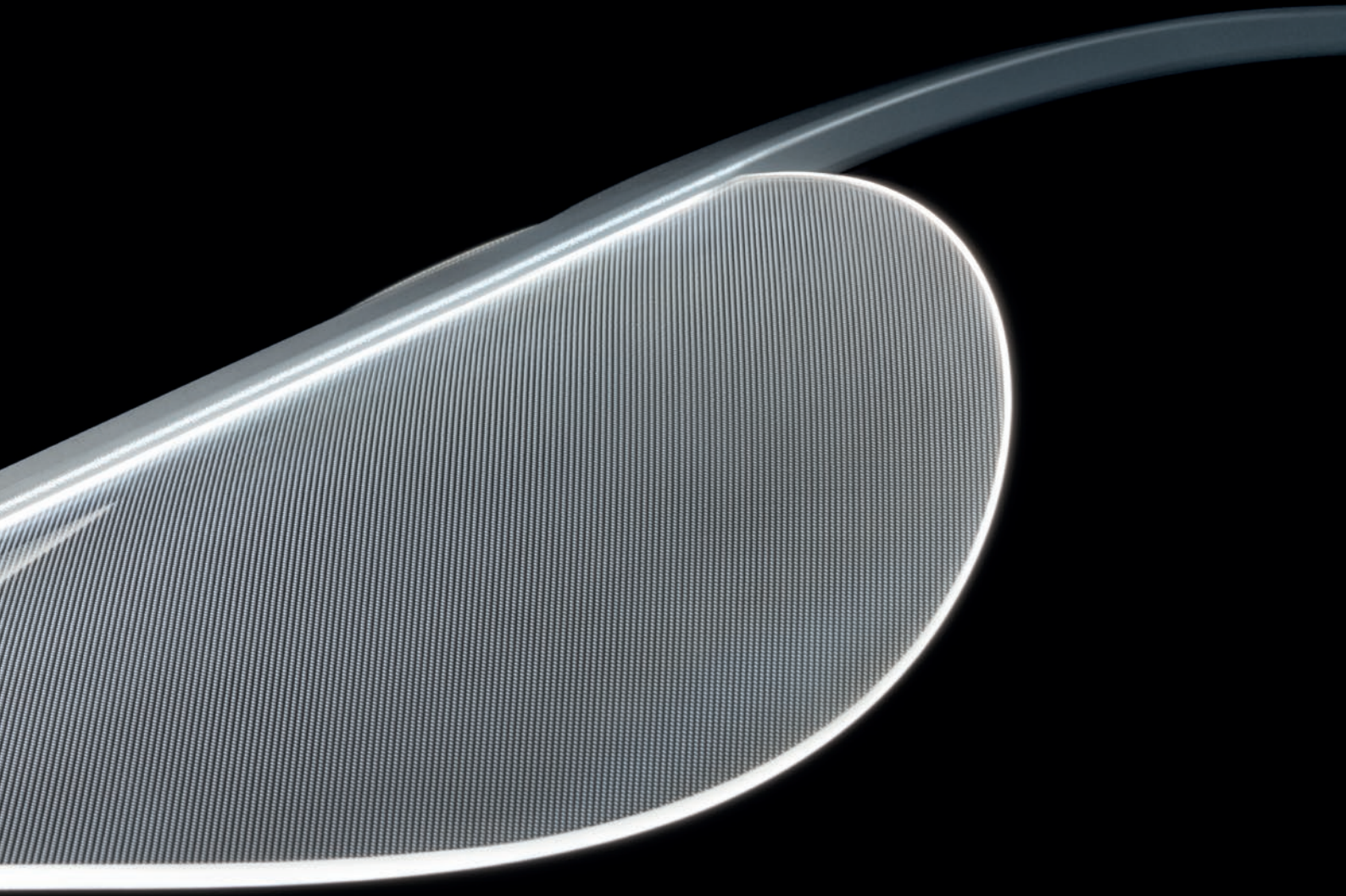

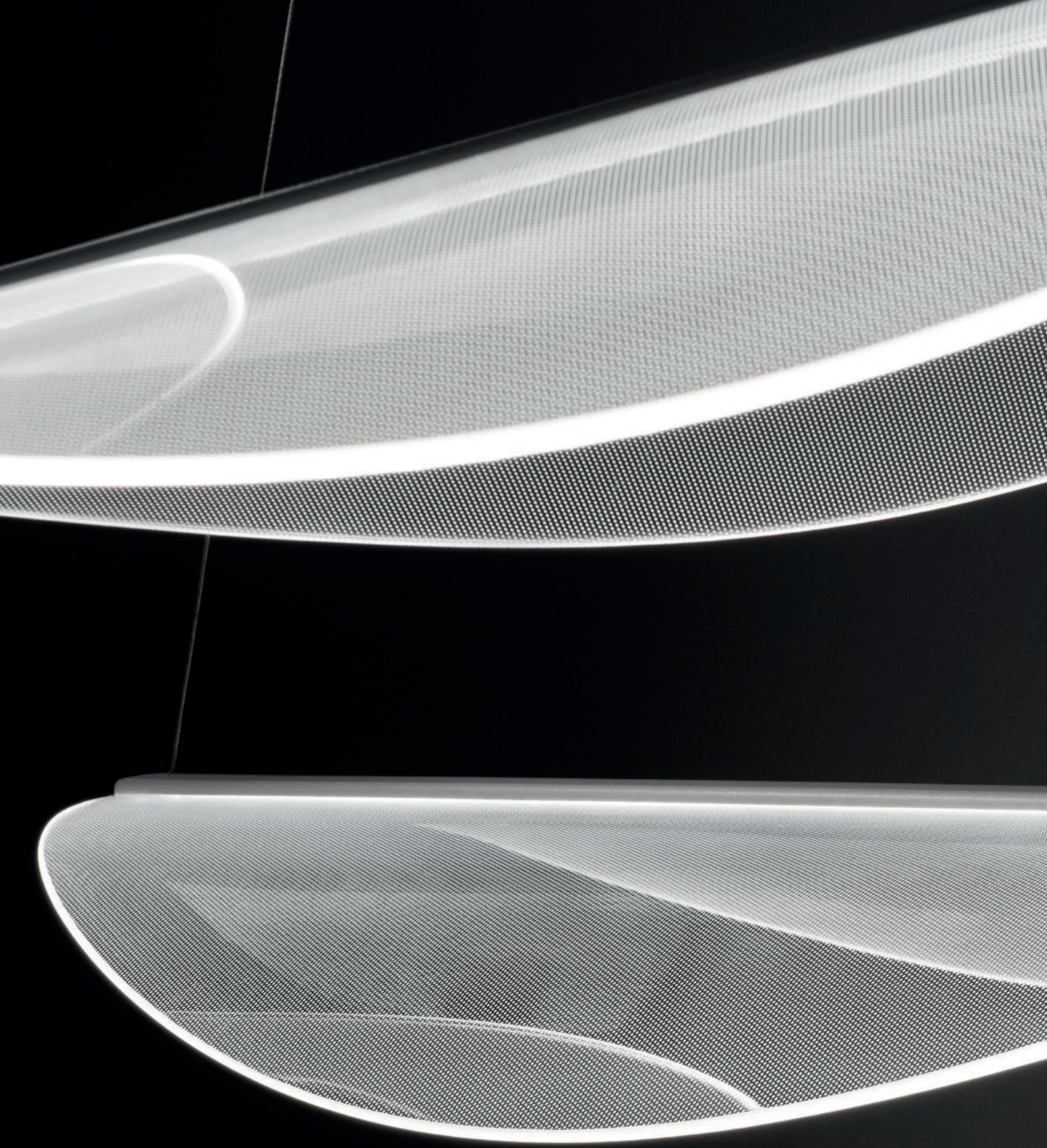

A loan from botany, a slight silhouette.

A thin white painted aluminum bar houses the LED light source, a clean light fills the screen-printed PMMA diffuser that distributes it downward. The extreme transparency is in contrast to the brightness of the lamp lit, embellished with a characteristic pattern of laser micro-incisions (OptiLight Technology™). The pendant version seems like falling leaves driven by a light breeze. The free standing lamp has one leaf, large and bright, which connotes the environments

Diphy

design Linea Light Group, 2016

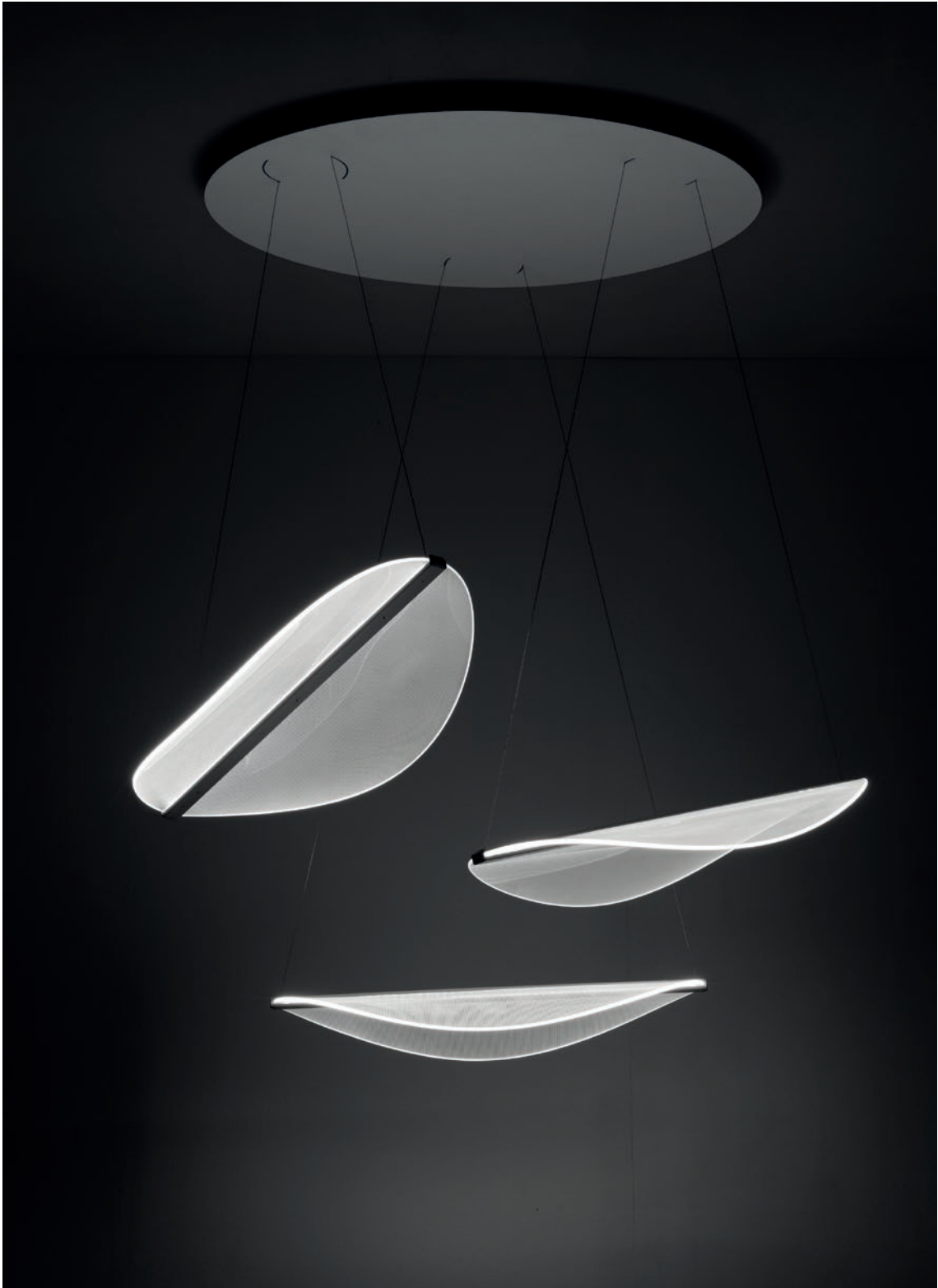





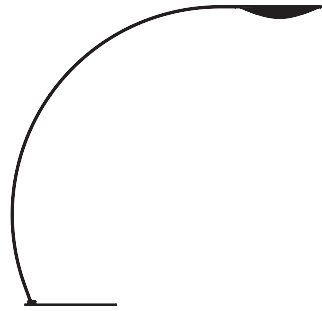

Technical Info

Diphy



.A thin leaf fluctuates
in the air. Light,
transparent,
and almost ethereal.







Luminous wings for suggestive geometric plays. Reinventing minimal sculpture's lightness and elegance. Antiglare polycarbonate diffuser fixed on two thin aluminum rods, indirect light white wings decorating walls with suggestive chiaroscuro games. Wings grants functional luminous compositions with special effects solution. Combining two different sizes creates suggestive geometric games

.Wings

design Linea Light Group, 2012









Technical Info

Wings_W | Wall light | 220-240 V | topLED 10 W



type

White	CRI 85	7411
Black	CRI 85	7412

colour

3000 K 690 lm

optics

diffused

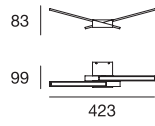

Wings_W | Wall light | 220-240 V | topLED 15 W



type

White	CRI 85	7414
Black	CRI 85	7415

colour

3000 K 1380 lm

optics

diffused

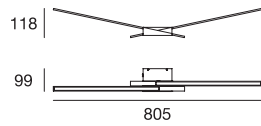

.Wings



.A figurative reference to flight, suggestion that becomes furniture.



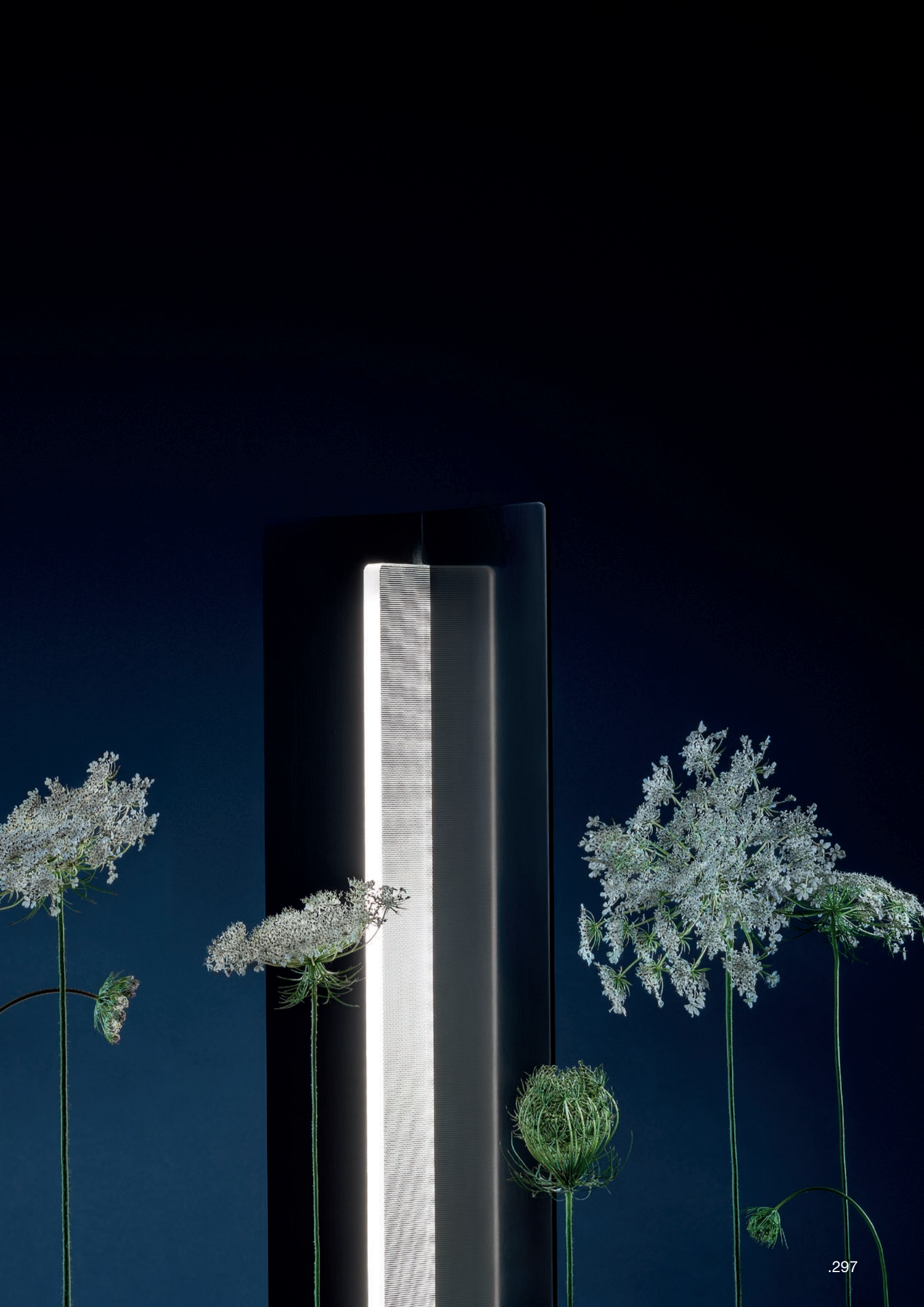



Thin and elegant. Fairly and touchable. An elegant and thin diffuser is encapsulated in extra-light rectangular, aluminum finish lamp body. Flurry, designed by Marco Piva, is available in three elegant finishes: polished white, brushed/satin brass or brushed/satin black. The inner side has a double finish, part satin and part polished, a choice granting an innovative sensual material perception. Wall or ceiling mounted is available in three different sizes, suitable for every designer's needs

.Flurry

design Marco Piva, 2016

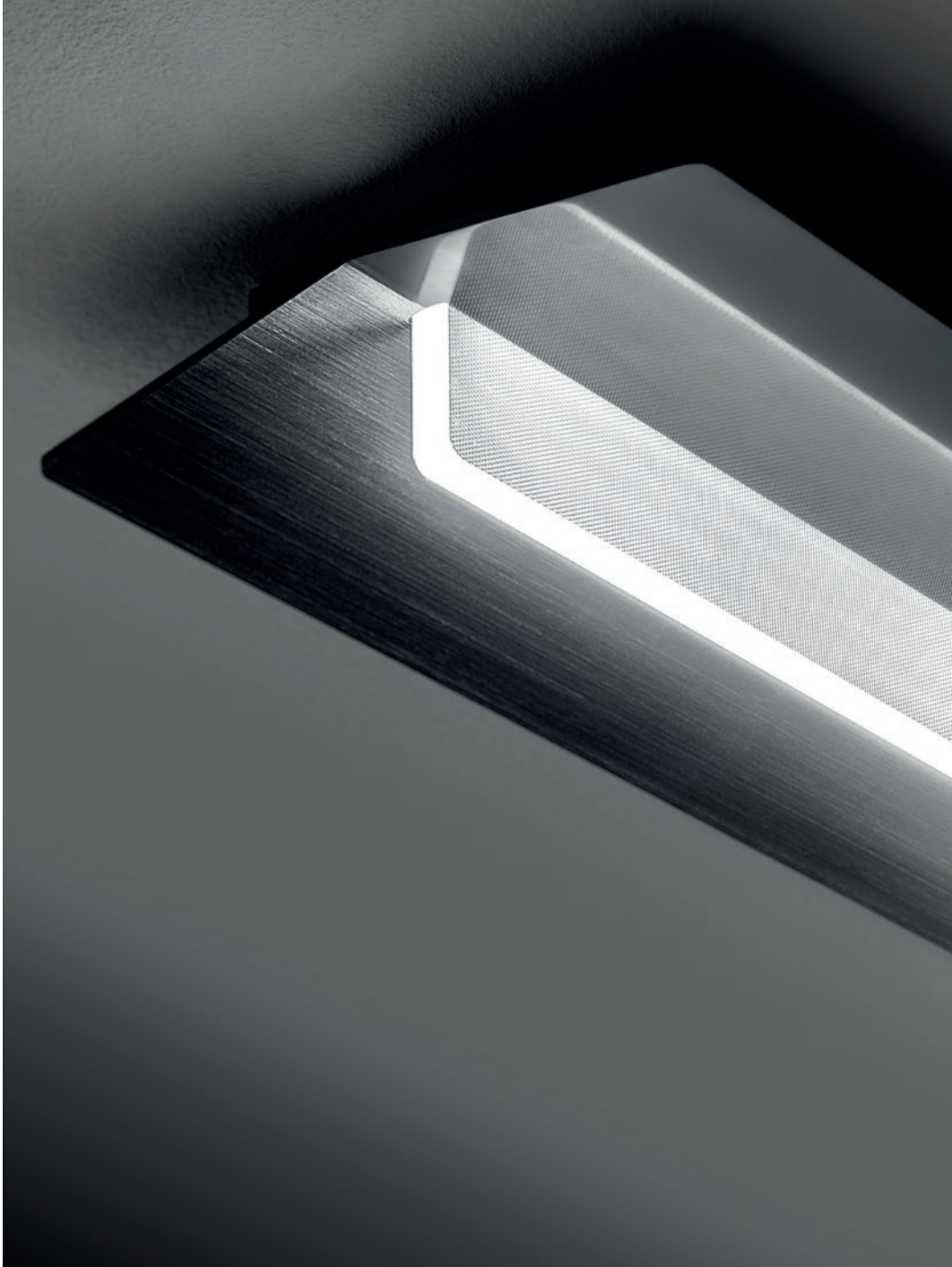







Technical Info

Flurry_S | Ceiling luminaires | 220-240 V | 24 W



type

White	CRI 90	7963
Black	CRI 90	7964
Bronze	CRI 90	7965

colour

3000 K 2702 lm

optics

diffused

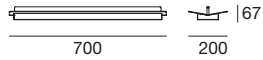

Flurry_S | Ceiling luminaires | 220-240 V | 45 W



type

White	CRI 90	7966
Black	CRI 90	7967
Bronze	CRI 90	7968

colour

3000 K 5073 lm

optics

diffused

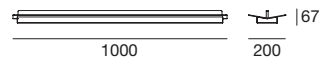

Flurry_S | Ceiling luminaires | 220-240 V | 59 W



type

White	CRI 90	7969
Black	CRI 90	7970
Bronze	CRI 90	7971

colour

3000 K 6764 lm

optics

diffused

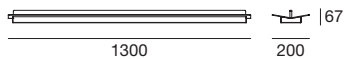

cod. 7965_7968_7971
Flurry_S
Ceiling luminaires



.Flurry



.The linear light is reflected by textured surfaces and is diffused into the surrounding environment with sophisticated and yet sober effects.

cit. Marco Piva







An Eclipse which obscures and spreads up a perfect light. Created by designer Oriano Favaretto, this lamp is able to define dynamic light textures. Eclips fans out with its rotating aluminum elements and the acid-etched white glass mobile diffuser which create chiaroscuro oblique and unexpected lighting effects. Available in several precious chromatic combinations, in ceiling and wall versions. The first one suitable to light a dining table or a contemporary living space. Wall mounted, smaller option, composable to create modular and acrobatic lighting games

.Eclips

design Oriano Favaretto, 2016

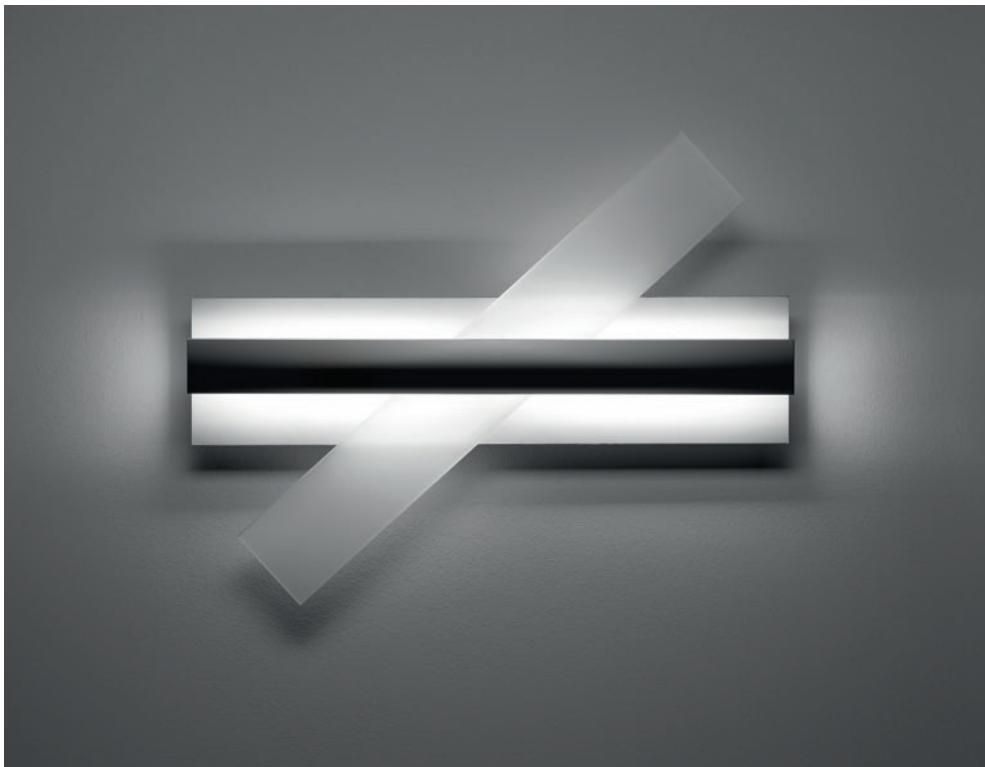
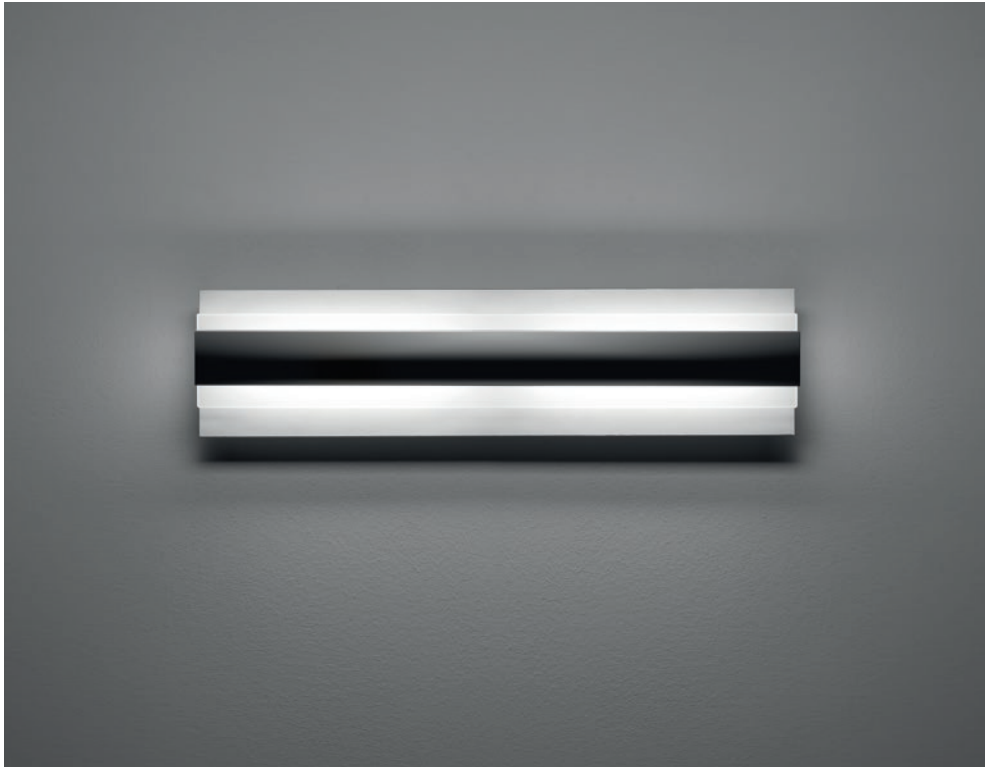





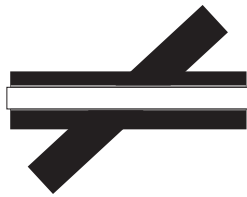

Technical Info

Eclips_W | Wall light | 220-240 V | 20 W

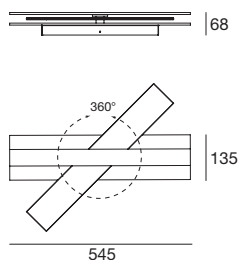

type

White	CRI 90	8150
Wh. Al.	CRI 90	8151
Cha. Bl.	CRI 90	8152
Bl. Cha.	CRI 90	8153

colour

3000 K 2300 lm

optics

diffused

Eclips_S | Ceiling luminaires | 220-240 V | 36 W

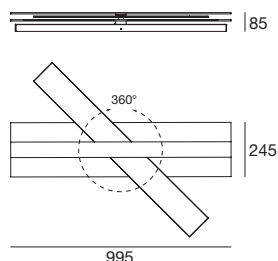

type

White	CRI 90	8155
Wh. Al.	CRI 90	8156
Cha. Bl.	CRI 90	8157
Bl. Cha.	CRI 90	8158

colour

3000 K 4188 lm

optics

diffused

cod. 8156
Eclips_S
 Ceiling luminaires



.Eclips



.I was looking for my ideal
luminous landscape,
but our needs change,
just like our moods.
I was waiting for a light eclipse.

cit. Oriano Favaretto





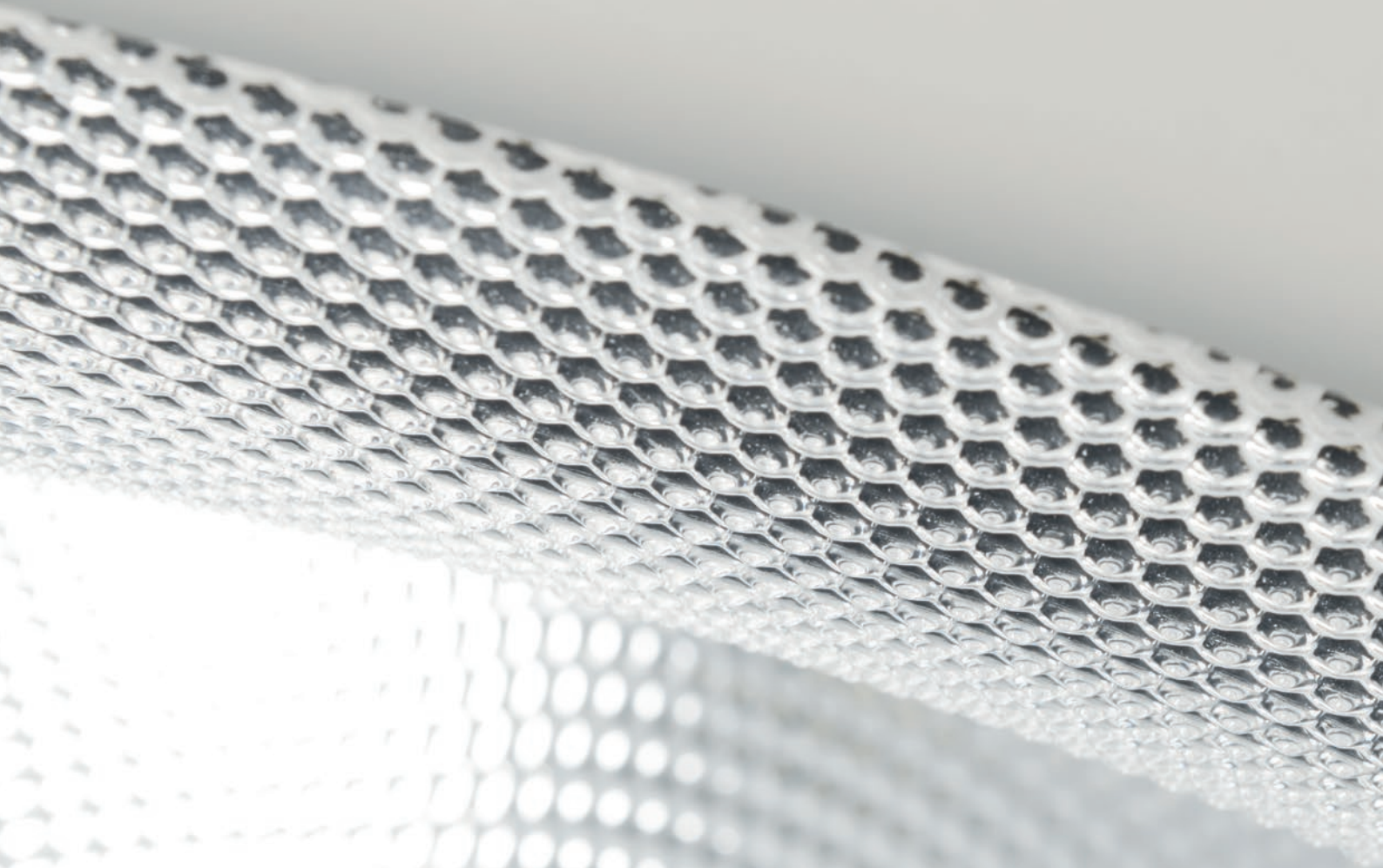

White lighting suspended rock.

An irregular shape defined by designers Anton Petrov and Ilya Korchagin, a polished luminous pebble. A suspension or ceiling lamp defined by smooth lines, creating interesting chiaroscuro games. Body lamp in opal white polythene with a two options diffuser, opal white or micro-prismatic, offering a dynamic light vision. Dunia is ideal to light residential spaces

.Dunia

design Anton Petrov e Ilya Korchagin, 2012









Technical Info

Dunia_P | Pendant luminaires | 220-240 W | 3xE27 | White Diffuser

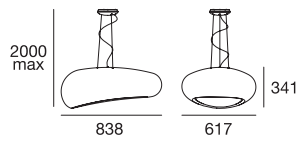

type

White **7470**

colour

3x46 W max

optics

diffused

Dunia_P | Pendant luminaires | 220-240 W | 3xE27 | Prismatic Diffuser

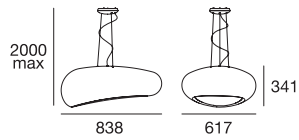

type

White **7473**

colour

3x46 W max

optics

diffused

Dunia_S | Ceiling luminaires | 220-240 W | 3xE27 | White Diffuser

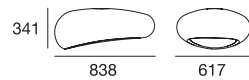

type

White **7471**

colour

3x46 W max

optics

diffused

Dunia_S | Ceiling luminaires | 220-240 W | 3xE27 | Prismatic Diffuser

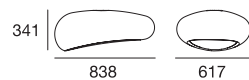

type

White **7472**

colour

3x46 W max

optics

diffused

.Dunia

.Winner of a competition
organized by the University of Moscow,
it was born of the creative
minds of young designers
Anton Petrov and Ilya Korchagin.







Organic, ironic and playful shape.

Dynamic is an organic shape applique; light vibrates under the satin blown glass. The satin polycarbonate frame allows a quick and easy bayonet fixing. The refined opal white, due to venetian blown masters, grants a homogeneous and diffusive light beam, around the space. Available in two options, wall or ceiling mounted, and in three diameters, allowing free and funny compositions

.Dynamic

design Linea Light Group, 2010









Technical Info

Dynamic_W | Wall light | 220-240 V | topLED 6 W

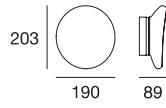

type

White CRI 90 **7785**

colour

3000 K 574 lm

optics

diffused

Dynamic_W | Wall light | 220-240 V | topLED 21 W

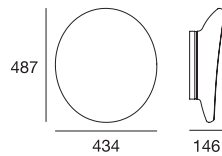

type

White CRI 90 **7786**

colour

3000 K 2655 lm

optics

diffused

Dynamic_W | Wall light | 220-240 V | topLED 30 W

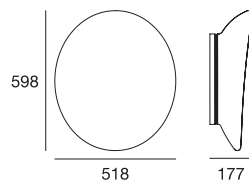

type

White CRI 90 **7787**

colour

3000 K 3730 lm

optics

diffused

.Dynamic



.Inspired by the dynamic
movement of small but
vital red globules.

Designer

Pio & Tito Toso

“Much of our work begins with a receptive attitude to individuate the premises of a project, a sort of genius loci that leads us to find the meaning of it, as well as a form of self-criticism that always makes us question what we are doing, that encourages us to ask ourselves what is the ultimate meaning of each sign.

Architects & designers
Founders of Pio&Tito Toso
Studio (Treviso, IT)
Products: Oxygen, Quad, Oblix



Davide Oppizzi

“Inspiration comes when we open our eyes to life! Life in all its aspects, including nature, society, philosophy and technology. The affirmation of a trend stems from the challenges the present poses to us. We live in an age where nearly everything is possible: having a boundless perspective provides constant inspiration without much effort on our part.”

Product and lighting designer
Founder of DCUBE Design
Espaces Lumière (Geneve, CH)
Product: 2Nights



Oriano Favaretto

“The origins are rural and visionary, while the passion is linked to the discovery of the thought hidden within matter; mind and matter that transform form and meaning. What drives me is the desire to furnish homes with items that have a strong emotional impact, modify spaces and atmospheres, and are able to live together with the history of man.”

Product and lighting
designer (Treviso, IT)
Products: Light game, Eclips



Marco Piva

“Emotion, fluidity and functionality. This is the language that characterizes my creations. I am a designer that loves travel, an innovator who, by training, favours rational approaches, and creates design solutions that reflect stylistic freedom and compositional simplicity.

Architect & designer
Founder of Studio Marco
Piva (Milan, IT)
Product: Flurry



Colin Johnson

“Clay is a tactile medium, so it is almost impossible not to convey some kind of emotion in the creative process. Some types of clay allow me to create strong architectural forms and mould interesting structures within which light and shapes can interact.”

Ceramist & designer
Founder of Lower Park Ceramics
(Hastings, East Sussex, UK)
Product: Moonflower



Anton Petrov & Ilya Korchagin

“The will to create an emotional point of reference, a comfortable, eco-friendly environment is an important factor in all our projects. In using natural materials like stone, wood, glass and metal we fill the space that we have created with the energy of nature.”

Architects & designers
Founders of ODS LAB
Bureau (Moscow, RU)
Product: Dunia



Code Index

CODE	PRODUCT	PAGE	CODE	PRODUCT	PAGE
6857	Mr.Magoo_S	205	7472	Dunia_S	324
6858	Mr.Magoo_P	203	7473	Dunia_P	324
6860	Mr.Magoo_P	203	7593	Tablet_P1	38
7100	Lama_FL	118	7594	Tablet_P1	38
7102	Lama_FL	118	7595	Tablet_S	38
7104	Lama_W	117	7596	Tablet_S	38
7106	Lama_P1	116	7598	Tablet_P2	38
7107	Lama_W	117	7599	Tablet_P2	38
7108	Lama_P1	116	7600	Tablet_W1	40
7109	Lama_S	117	7601	Tablet_W1	40
7111	Lama_S	117	7602	Tablet_W1	40
7112	Lama_Tab	118	7604	Tablet_W1	41
7114	Lama_Tab	118	7605	Tablet_W1	41
7116	Lama_FL office	118	7606	Tablet_W2	39
7117	Lama_FL office	118	7607	Tablet_W2	39
7118	Lama_P2	116	7608	Tablet_W1	40
7119	Lama_P2	116	7609	Tablet_W1	40
7411	Wings_W	294	7610	Tablet_W1	40
7412	Wings_W	294	7611	Tablet_W1	41
7414	Wings_W	294	7612	Tablet_W1	41
7415	Wings_W	294	7613	Tablet_W2	39
7440	Next_S	272	7614	Tablet_W2	39
7441	Next_S	272	7650	Saturn_P	128
7442	Next_S	272	7651	Saturn_S	129
7444	Next_P	274	7652	Saturn_P	128
7445	Next_C	273	7653	Saturn_S	129
7447	Next_W	274	7654	Saturn_W	130
7460	Circle Wave_P	76	7660	Entourage_P2	180
7461	Circle Wave_S	76	7661	Entourage_P2	180
7462	Circle Wave_P	76	7662	Entourage_P2	180
7463	Circle Wave_S	76	7663	Entourage_P1	179
7465	Branch_P	252	7664	Entourage_P1	179
7466	Branch_P	252	7665	Entourage_P1	179
7470	Dunia_P	324	7666	Entourage_P1	179
7471	Dunia_S	324	7667	Entourage_P1	179

CODE	PRODUCT	PAGE	CODE	PRODUCT	PAGE
7668	Entourage_P1	179	7775	Xilema_WJ	221
7669	Entourage_P1	179	7776	Xilema_WJ	221
7670	Entourage_P1	179	7777	Xilema_W1	221
7671	Entourage_P1	179	7778	Xilema_W1	221
7676	Entourage_P1	178	7785	Dynamic_W	334
7677	Entourage_P1	178	7786	Dynamic_W	334
7678	Entourage_P1	178	7787	Dynamic_W	334
7682	Square_SQ	165	7788	Mr.Magoo_P	202
7690	Square_SQ	165	7789	Mr.Magoo_S	204
7694	Entourage_P1	178	7790	Mr.Magoo_P	203
7695	Entourage_P1	178	7792	Mr.Magoo_S	205
7696	Entourage_P1	178	7799	Mr.Magoo_S	205
7697	Entourage_P1	178	7942	2Nights_W1	86
7698	Entourage_P1	178	7943	2Nights_W2	86
7699	Entourage_P1	178	7944	2Nights_W1	86
7740	Kyklos_W	142	7945	2Nights_W2	86
7741	Kyklos_W	142	7960	Oblix	152
7745	Light Game_S	232	7961	Oblix	152
7746	Light Game_P	232	7963	Flurry_S	304
7747	Light Game_S	232	7964	Flurry_S	304
7748	Light Game_P	232	7965	Flurry_S	304
7750	Quad_W	54	7966	Flurry_S	304
7753	Quad_W	54	7967	Flurry_S	304
7760	Moonflower	101	7968	Flurry_S	304
7761	Moonflower	101	7969	Flurry_S	304
7765	Xilema_W1	221	7970	Flurry_S	304
7766	Xilema_W1	221	7971	Flurry_S	304
7767	Xilema_W2	221	7975	2Nights_W1	86
7768	Xilema_W2	221	7976	2Nights_W2	86
7769	Xilema_S	220	7977	2Nights_W1	86
7770	Xilema_S	220	7978	2Nights_W2	86
7771	Xilema_FL	222	7980	Kyklos_P1	140
7772	Xilema_FL	222	7981	Kyklos_P1	140
7773	Xilema_P	220	7982	Kyklos_P1	140
7774	Xilema_P	220	7983	Kyklos_P2	141

Code Index

CODE	PRODUCT	PAGE	CODE	PRODUCT	PAGE
7984	Kyklos_P2	141	8083	Oxygen_S	25
7985	Kyklos_P2	141	8084	Oxygen_S	25
7987	Square_SR	166	8085	Oxygen_S	25
7988	Square_SR	166	8086	Oxygen_S	25
7989	Square_PR	166	8087	Oxygen_S	25
7990	Square_PR	166	8088	Oxygen_S	25
7991	Square_SR	166	8089	Oxygen_P	24
7992	Square_SR	166	8090	Oxygen_P	24
7993	Square_PR	166	8091	Oxygen_P	24
7994	Square_PR	166	8092	Oxygen_P	24
7995	Square_SQ	165	8093	Oxygen_P	24
7996	Square_PQ	164	8094	Oxygen_P	24
7997	Square_PQ	164	8095	Oxygen_P	24
7998	Square_SQ	165	8096	Oxygen_P	24
7999	Square_SQ	165	8097	Oxygen_FL	26
8000	Square_PQ	164	8098	Oxygen_FL	26
8001	Square_PQ	164	8099	Oxygen_FL	26
8002	Square_SQ	165	8100	Oxygen_FL	26
8003	Square_PQ	164	8101	Oxygen_FL	26
8004	Square_PQ	164	8102	Oxygen_FL	26
8005	Mr.Magoo_P	202	8103	Oxygen_FL	26
8006	Mr.Magoo_S	204	8104	Oxygen_FL	26
8007	Mr.Magoo_P	202	8105	Oxygen_W	26
8008	Mr.Magoo_S	204	8106	Oxygen_W	26
8009	Mr.Magoo_FL	206	8107	Oxygen_W	26
8022	Monarque_P	262	8108	Oxygen_W	26
8023	Monarque_P	262	8110	Quad_P2	54
8024	Monarque_P	262	8111	Quad_P2	54
8025	Monarque_P	262	8112	Quad_P3	54
8035	Opti-Line_P	190	8113	Quad_P3	54
8036	Opti-Line_P	190	8114	Quad_P1	54
8037	Opti-Line_P	190	8115	Quad_P1	54
8038	Opti-Line_P	190	8140	Mongolfier_P1	64
8081	Oxygen_S	25	8141	Mongolfier_P1	64
8082	Oxygen_S	25	8144	Mongolfier_P2	64

CODE	PRODUCT	PAGE	CODE	PRODUCT	PAGE
8145	Mongolfier_P2	64	KIT0020	Driver	87
8150	Eclips_W	314	KIT0021	Driver	87
8151	Eclips_W	314	KIT0035	Accessories	87
8152	Eclips_W	314	KIT0036	Accessories	87
8153	Eclips_W	314	KIT0041	Accessories	42
8155	Eclips_S	314	KIT0042	Accessories	42
8156	Eclips_S	314	KIT0043	Accessories	42
8157	Eclips_S	314	KIT0044	Accessories	42
8158	Eclips_S	314	KIT0045	Accessories	42
8165	Diphy_FL	284	KIT0046	Accessories	42
8168	Diphy_P	284	KIT0047	Accessories	42
8175	Madame Blanche_P1	242	KIT0048	Accessories	101
8178	Madame Blanche_P2	242	KIT0049	Accessories	101
8185	Oxygen_W	26	KIT0050	Accessories	101
8186	Oxygen_W	26	KIT0051	Accessories	102
8187	Oxygen_W	26	KIT0052	Accessories	102
8188	Oxygen_W	26	KIT0053	Accessories	102
84865	Accessories	103	KIT0054	Accessories	102
84869	Accessories	103	KIT0055	Accessories	87
84885	Accessories	103	KIT0056	Accessories	87
84895	Accessories	103	KIT0057	Accessories	87
84994	Accessories	103	KIT0058	Accessories	87
89186	Accessories	103	KIT80	Accessories	42
89189	Accessories	103	KIT81	Accessories	42
98140	Accessories	103	KIT82	Accessories	42
98493	Accessories	103	KIT83	Accessories	42
99045	DMX Controller	103	KIT84	Accessories	42
99046	DMX Controller	103			
99050	DMX Controller	103			
99234	DMX Controller	103			
99235	DMX Controller	103			
99346	Accessories	103			
99184	Accessories	103			
KIT0011	Control Unit	102			
KIT0019	Driver	87			

Symbols

	Indoor installation		Article protected by resin potting
	Outdoor installation		Available in emergency version
	Wall mounting		Round installation hole
	Ground mounting		Quadrangular installation hole
	Ceiling mounting		Single emission luminaire
	Wall or ground mounting		Double emission luminaire
	Ceiling or wall mounting		Device suitable to be mounted on furniture
	Ceiling, wall or ground mounting		Device suitable to be mounted on normally flammable surfaces (EN 60598)
	Ceiling or ground mounting		Device with integrated thermal protection
	Stainless steel		Simply Dim
	Protection class (IEC 60529) against foreign bodies and water		1-10 V
	Protection degrees (IEC 62262) against external mechanical impacts		DMX 512
	Directional light beam		DALI
	Tilting light beam	c.c.	Constant Current
	Walk-over lighting fixture	c.v.	Constant Voltage
	Drive-over lighting fixture (2,500 kg)		P.I.R. sensor
	Power supply cable included		R.F. remote control
	Class I - IEC protection class		Infrared
	Class II - IEC protection class		Dimming
	Class III - IEC protection class		Push DIM
	Driver included		Warm Tune
	Driver not included		
	Over Voltage Protection		

All articles belong to energy class A++.
The lumens indicated refer to the light source emission.
The connection diagrams for electronics articles are included in the technical documentation.

How to

Family

Product information

Composition table:
code - colour - optics

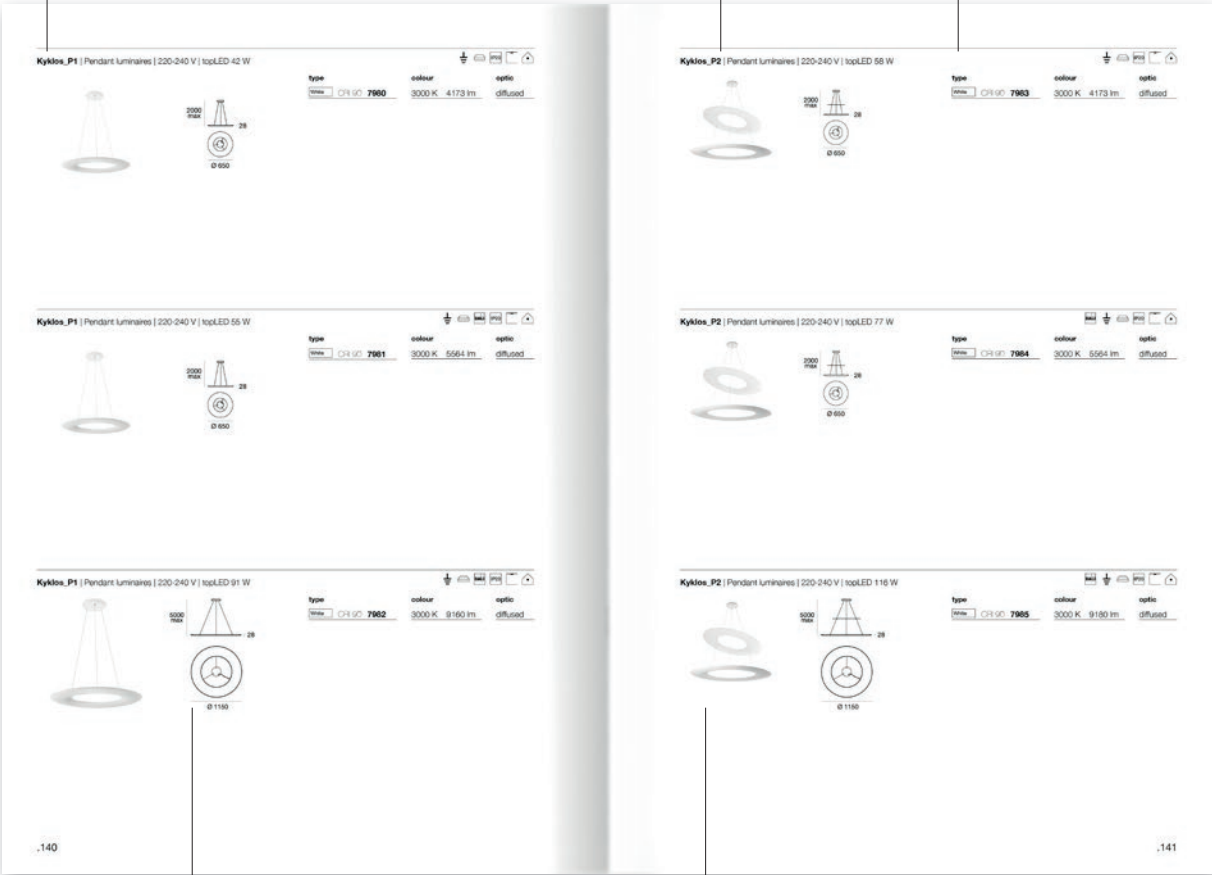

Dimensioned
technical drawing

Product
detail

Finishes

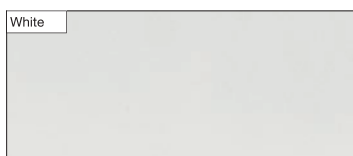

White | RAL 9003 embossed

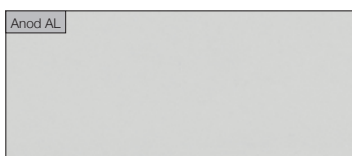

Anodized aluminium

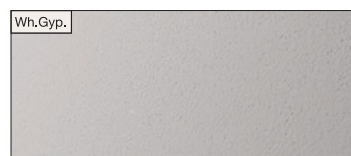

Gypsum white

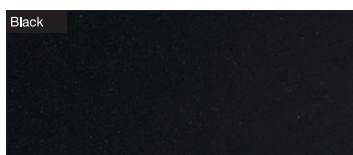

Black | RAL 9005 embossed



Yellow

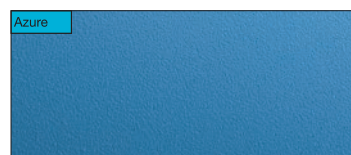

Azure

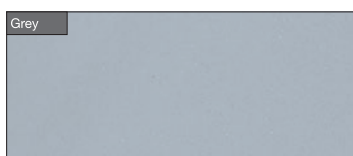

Grey | RAL 9006 embossed



Stone Grey

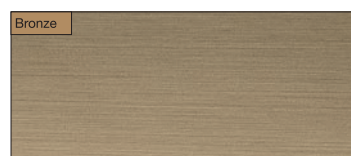

Bronze

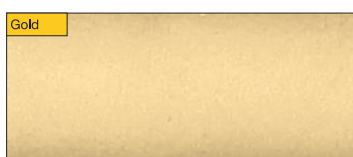

Gold | Warm & Chic

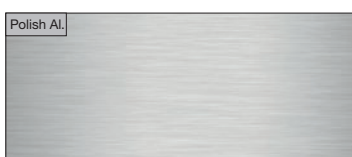

Polished aluminium

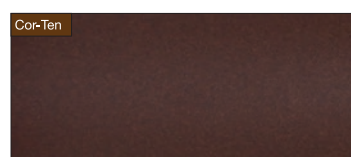

Cor-Ten | Finish

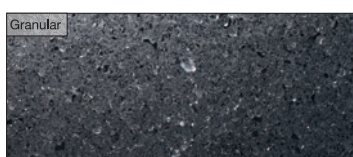

Granular

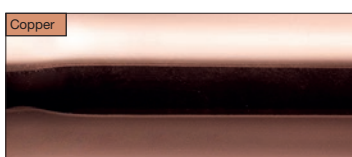

Copper

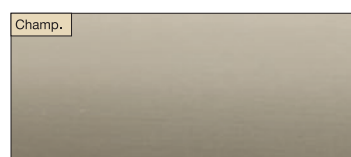

Champagne

Addresses

Linea Light S.r.l. Italy

via della Fornace, 59 z.i.
31023 Castelmio di Resana (TV) - Italy
Phone: +39 0423 78 68
Fax: +39 0423 78 69 00
info@linealight.com

LightVillage Milano - Exhibition Area Only

via Morimondo, 26 int. 17G
20143 Milano
Phone: +39 02 36750915
Fax: +39 02 36750915
milano@lightvillage.it

Linea Light France

Z.A. Heiden Est, 12 rue des Pay-Bas
68310 Wittelsheim - France
Phone: +33 389 75 52 23
Fax: +33 389 75 59 07
info@linealight.fr

Linea Light UK Ltd

Suite 109 - Business Design Centre
52 Upper Street - Islington N10QH - London - UK
Phone: +44 0203 6371983
info@linealight-uk.com

Linea Light Deutschland GmbH

Aktienstraße 214
45473 Mülheim a.d. Ruhr - Germany
Phone: +49 208 299979-0
Fax: +49 208 299979-10
service@linealight.de

Linea Light GCC - Middle East & Gulf Countries

Jumeirah Lake Towers
JBC2 - 35th Floor Office 02 - Dubai - UAE
P.O. Box 125902
Phone: +971 4 4218275
Fax: +971 4 4218274
info@linealight.ae

Linea Light Polska Sp. z.o.o.

ul. Wiosenna, 47
41253 Czeladz - Poland
Phone: +48 32 265 11 21
Fax: +48 32 265 04 42
biuro@linealight.com.pl

Linea Light Russia

Luzhnetskaya nab., 2/4, str. 3, of. 304
119270 Moscow - Russian Federation
Phone: +7 495 639 99 41
info@linealight.ru

Linea Light USA | Inter Lux

3741 Commerce Drive
Suites 306-308
Baltimore, MD 21227 - USA
Phone: +1 410 381 1497
Fax: +1 410 381 1589
answers@inter-lux.com

Linea Light Asia-Pacific Ltd

YuXiang Industrial Area
528478 HengLan Town, ZhongShan City,
GuangDong Province, China
Phone: +86 760 87618355
Fax: +86 760 87553990
info@linealight.cn



linealight.com

The drawings, dimensions, materials and colours contained in this catalogue are merely indicative.

In the customers' interest, the Company reserves the right to modify the models at any time without notice.

Art direction:

Linea Light Group - Marketing Dept.

Concept:

SR Communication Solution

Photographers:

Giorgio Gori - Oak Seed Studio

Studio Pointer [A.D. S. Bortoletto_Styling V. Brunetta]

Cl.BO. Creative Lab

Copywriter:

Andrea Pietro Calatroni

Pre-press:

Studio Pointer

Press:

Nava Press

Thanks to:

INFINITI - OMP CHAIRS

Printed in Italy

October 2016

Linea Light Group - Product Design Dept.

Mirco Crosatto [Tablet_Circle Wave_Lama_Opti-Line_Mr. Magoo_Madame Blanche_Next]

Edin Dedovic [Xilema_Wings]

Manuel Remeggio [Branch_Dynamic]

